



# INDUSTRIAL AIR COMPRESSOR LS-10

AIR-COOLED AND WATER-COOLED  
25, 30 & 40 HP  
18, 22 & 30 KW  
STANDARD & 24 KT

OPERATOR'S  
MANUAL AND  
PARTS LIST

KEEP FOR  
FUTURE  
REFERENCE

Part Number 02250118-200  
eSullair Corporation

*Manual Brought to You By: [IndustrialAirPower.com](http://IndustrialAirPower.com)*

## **AIR CARE SEMINAR TRAINING**

Sullair Air Care Seminars are 3-day courses that provide hands-on instruction in the proper operation, maintenance and service of Sullair equipment. Individual seminars on Industrial compressors and compressor electrical systems are presented at regular intervals throughout the year at a dedicated training facility at Sullair's corporate headquarters in Michigan City, Indiana.

Instruction includes discussion of the function and installation of Sullair service parts, troubleshooting of the most common problems, and actual equipment operation. The seminars are recommended for maintenance and service personnel.

For detailed course outlines, schedule and cost information contact:

Sullair Corporate Training Department  
1-888-SULLAIR or 219-879-5451 (ext. 5363)

- Or Write -

Sullair Corporation  
3700 E. Michigan Blvd.  
Michigan City, IN 46360  
Attn: Service Training Department

## TABLE OF CONTENTS

### Section 1 **SAFETY**

<b>PAGE</b>	
1	1.1 GENERAL
1	1.2 PERSONAL PROTECTIVE EQUIPMENT
1	1.3 PRESSURE RELEASE
2	1.4 FIRE AND EXPLOSION
2	1.5 MOVING PARTS
2	1.6 HOT SURFACES, SHARP EDGES AND SHARP CORNERS
2	1.7 TOXIC AND IRRITATING SUBSTANCES
3	1.8 ELECTRICAL SHOCK
3	1.9 LIFTING
4	1.10 ENTRAPMENT

### Section 2 **DESCRIPTION**

5	2.1 INTRODUCTION
5	2.2 DESCRIPTION OF COMPONENTS
5	2.3 SULLAIR COMPRESSOR UNIT, FUNCTIONAL DESCRIPTION
6	2.4 COMPRESSOR COOLING AND LUBRICATION SYSTEM, FUNCTIONAL DESCRIPTION
9	2.5 COMPRESSOR DISCHARGE SYSTEM, FUNCTIONAL DESCRIPTION
9	2.6 CONTROL SYSTEM, FUNCTIONAL DESCRIPTION- STANDARD ELECTRO-MECHANICAL
11	2.7 CONTROL SYSTEM, FUNCTIONAL DESCRIPTION- SUPERVISOR II
12	2.8 AIR INLET SYSTEM, FUNCTIONAL DESCRIPTION
12	2.9 INSTRUMENT PANEL GROUP, FUNCTIONAL DESCRIPTION- STANDARD ELECTRO-MECHANICAL CONTROLLER

### Section 3 **SPECIFICATIONS**

15	3.1 TABLE OF SPECIFICATIONS
16	3.2 LUBRICATION GUIDE
16	3.3 APPLICATION GUIDE
17	3.4 LUBRICATION CHANGE RECOMMENDATIONS AND MAINTENANCE

### Section 4 **INSTALLATION**

21	4.1 MOUNTING OF COMPRESSOR
21	4.2 VENTILATION AND COOLING
21	4.3 SERVICE AIR PIPING
22	4.4 COUPLING ALIGNMENT CHECK
22	4.5 FLUID LEVEL CHECK
22	4.6 ELECTRICAL PREPARATION- STANDARD ELECTRO- MECHANICAL

## TABLE OF CONTENTS

(CONTINUED)

Section 4		
<b>INSTALLATION</b>	<b>PAGE</b>	
(CONTINUED)	<b>23</b>	4.7 ELECTRICAL PREPARATION- SUPERVISOR II
	<b>23</b>	4.8 MOTOR ROTATION DIRECTION CHECK
Section 5		
<b>OPERATION-</b>	<b>25</b>	5.1 GENERAL
<b>ELECTRO-MECHANICAL</b>	<b>25</b>	5.2 PURPOSE OF CONTROLS- STANDARD ELECTRO-MECHANICAL
	<b>27</b>	5.3 INITIAL START-UP PROCEDURE- STANDARD ELECTRO-MECHANICAL
	<b>27</b>	5.4 SUBSEQUENT START-UP PROCEDURE- STANDARD ELECTRO-MECHANICAL
	<b>27</b>	5.5 SHUTDOWN PROCEDURE- STANDARD ELECTRO-MECHANICAL
Section 6		
<b>OPERATION-</b>	<b>29</b>	6.1 INTRODUCTION
<b>SUPERVISOR II</b>	<b>29</b>	6.2 KEYPAD
	<b>29</b>	6.3 STATUS DISPLAYS
	<b>30</b>	6.4 LAMP INDICATORS
	<b>31</b>	6.5 OPERATION INTRODUCTION
	<b>31</b>	6.6 SUPERVISOR II PARAMETER SETUP
	<b>32</b>	6.7 OPERATING THE COMPRESSOR
	<b>33</b>	6.8 PURPOSE OF CONTROLS- SUPERVISOR II
	<b>34</b>	6.9 SUPERVISOR II OUTPUT RELAYS
	<b>34</b>	6.10 INITIAL START-UP PROCEDURE- SUPERVISOR II
	<b>35</b>	6.11 SUBSEQUENT START-UP PROCEDURE- SUPERVISOR II
	<b>35</b>	6.12 SHUTDOWN PROCEDURE- SUPERVISOR II
Section 7		
<b>MAINTENANCE</b>	<b>37</b>	7.1 GENERAL
	<b>37</b>	7.2 DAILY OPERATION
	<b>37</b>	7.3 MAINTENANCE AFTER INITIAL 50 HOURS OF OPERATION
	<b>37</b>	7.4 MAINTENANCE EVERY 1000 HOURS
	<b>37</b>	7.5 FLUID MAINTENANCE
	<b>37</b>	7.6 FILTER MAINTENANCE
	<b>37</b>	7.7 SEPARATOR MAINTENANCE
	<b>37</b>	7.8 PARTS REPLACEMENT AND ADJUSTMENT PROCEDURES
	<b>40</b>	7.9 TROUBLESHOOTING- STANDARD ELECTRO-MECHANICAL

## TABLE OF CONTENTS

(CONTINUED)

### Section 7 MAINTENANCE (CONTINUED)

PAGE	
42	7.10 TROUBLESHOOTING- SUPERVISOR II
44	7.11 CALIBRATION

### Section 8 ILLUSTRATIONS AND PARTS LIST

49	8.1 PROCEDURE FOR ORDERING PARTS
49	8.2 RECOMMENDED SPARE PARTS LIST
50	8.3 MOTOR, COMPRESSOR, FRAME AND PARTS
54	8.4 COOLER ASSEMBLY
56	8.5 AIR INLET SYSTEM
58	8.6 COOLING AND LUBRICATION SYSTEM- AIR-COOLED
62	8.7 COOLING AND LUBRICATION SYSTEM- WATER-COOLED 25-303HP/ 18-22KW
66	8.8 COOLING AND LUBRICATION SYSTEM- WATER-COOLED 40HP/ 30KW
70	8.9 DISCHARGE SYSTEM
74	8.10 CONTROL SYSTEM AND ELECTRICAL PARTS
78	8.11 INSTRUMENT PANEL
80	8.12 ENCLOSURE
82	8.13 DECAL GROUP
88	8.14 DECAL LOCATIONS
92	8.15 DECAL LOCATIONS- ENCLOSURE
94	8.16 WIRING DIAGRAM- ELECTRO-MECHANICAL (AIR-COOLED/WATER-COOLED)
95	8.17 WIRING DIAGRAM- SUPERVISOR II DELUXE (AIR-COOLED/WATER-COOLED)
96	8.18 WIRING DIAGRAM- WYE-DELTA ELECTRO-MECHANICAL (AIR-COOLED/WATER-COOLED)
97	8.19 WIRING DIAGRAM- WYE-DELTA SUPERVISOR II DELUXE (AIR-COOLED/WATER-COOLED)
98	8.20 WIRING DIAGRAM- WYE-DELTA ELECTRO-MECHANICAL (EUROPEAN) (AIR-COOLED/WATER-COOLED)
99	8.21 WIRING DIAGRAM- SUPERVISOR II (EUROPEAN) (AIR-COOLED/WATER-COOLED)

## 1.1 GENERAL

Sullair Corporation and its subsidiaries design and manufacture all of their products so they can be operated safely. However, the responsibility for safe operation rests with those who use and maintain these products. The following safety precautions are offered as a guide which, if conscientiously followed, will minimize the possibility of accidents throughout the useful life of this equipment.

The compressor should be operated only by those who have been trained and delegated to do so, and who have read and understood this Operator's Manual. Failure to follow the instructions, procedures and safety precautions in this manual can result in accidents and injuries. Read this manual prior to startup.

**NEVER** start the compressor unless it is safe to do so. **DO NOT** attempt to operate the compressor with a known unsafe condition. Tag the compressor and render it inoperative by disconnecting and locking out all power at source or otherwise disabling its prime mover, so others who may not know of the unsafe condition, cannot attempt to operate it until the condition is corrected.

Install, use and operate the compressor only in full compliance with all pertinent regulations and all applicable Federal, State, and Local codes, standards and regulations.

**DO NOT** modify the compressor and/or controls in any way except with written factory approval.

While not specifically applicable to all types of compressors with all types of prime movers, most of the precautionary statements contained herein are applicable to most compressors and the concepts behind these statements are generally applicable to all compressors.

## 1.2 PERSONAL PROTECTIVE EQUIPMENT

Prior to installing or operating the compressor, owners, employers and users should become familiar with, and comply with, all applicable regulations and any applicable Federal, State and Local codes, standards, and regulations relative to personal protective equipment, such as eye and face protective equipment, respiratory protective equipment, equipment intended to protect the extremities, protective clothing, protective shields and barriers and electrical protective equipment, as well as noise exposure administrative and/or engineering controls and/or personal hearing protective equipment.

## 1.3 PRESSURE RELEASE

**A.** Install an appropriate flow-limiting valve between the service air outlet and the shut-off (throttle) valve, either at the compressor or at any other point along the air line, when an air hose exceeding 1/2" (13mm) inside diameter is to be connected to the shut-off (throttle) valve, to reduce pressure in case

of hose failure, per all applicable Federal, State and Local codes, standards and regulations.

**B.** When the hose is to be used to supply a manifold, install an additional appropriate flow-limiting valve between the manifold and each air hose exceeding 1/2" (13mm) inside diameter that is to be connected to the manifold to reduce pressure in case of hose failure.

**C.** Provide an appropriate flow-limiting valve at the beginning of each additional 75 feet (23m) of hose in runs of air hose exceeding 1/2" (13mm) inside diameter to reduce pressure in case of hose failure.

**D.** Flow-limiting valves are listed by pipe size and rated CFM. Select appropriate valves accordingly, in accordance with their manufacturer's recommendations.

**E. DO NOT** use air tools that are rated below the maximum rating of the compressor. Select air tools, air hoses, pipes, valves, filters, and other fittings accordingly. **DO NOT** exceed manufacturer's rated safe operating pressures for these items.

**F.** Secure all hose connections by wire, chain or other suitable retaining devices to prevent tools or hose ends from being accidentally disconnected and expelled.

**G.** Open fluid filler cap only when compressor is **not running and is not pressurized**. Shut down the compressor and bleed the sump (receiver) to zero internal pressure before removing the cap.

**H.** Vent all internal pressure prior to opening any line, fitting, hose, valve, drain plug, connection or other component, such as filters and line oilers, and before attempting to refill optional air line anti-icer systems with antifreeze compound.

**I.** Keep personnel out of line with and away from the discharge opening of hoses or tools or other points of compressed air discharge.

**J.** Use air at pressures less than 30 psig (2.1 bar) for cleaning purposes, and then only with effective chip guarding and personal protective equipment.

**K. DO NOT** engage in horseplay with air hoses as death or serious injury may result.

**L. DO NOT** tamper with sump and unit (if provided) relief valves. Check the relief valve as recommended in the Maintenance Section of this manual or at a minimum of at least weekly to make sure it is not blocked, clogged, obstructed or otherwise disabled. **DO NOT** change the factory setting of the relief valve.

**M.** If the compressor is installed in an enclosed area, it is necessary to vent the relief valve to the outside of the structure or to an area of non-exposure.

# Section 1 SAFETY

## 1.4 FIRE AND EXPLOSION

### **⚠ WARNING**

When installing a Base Load Transfer (BLT) System, remove jumpers between 16-17 & 18-19 (Dual Control Compressors) so the other compressor does not backfeed defeating the shut-down circuitry.

- A.** Clean up spills of lubricant or other combustible substances immediately, if such spills occur.
- B.** Shut off the compressor and allow it to cool. Then keep sparks, flames and other sources of ignition away and **DO NOT** permit smoking in the vicinity when checking or adding lubricant or when refilling air line anti-icer systems with antifreeze compound.
- C. DO NOT** permit fluids, including air line anti-icer system antifreeze compound or fluid film to accumulate on, under, or around acoustical material, or on any external surfaces of the air compressor or on internal surfaces of the enclosure. Wipe down using an aqueous industrial cleaner or steam-clean as required. If necessary, remove acoustical material, clean all surfaces and then replace acoustical material. Any acoustical material with a protective covering that has been torn or punctured should be replaced immediately to prevent accumulation of liquids or fluid film within the material. **DO NOT** use flammable solvents for cleaning purposes.
- D.** Disconnect and lock out all power at source prior to attempting any repairs or cleaning of the compressor or of the inside of the enclosure, if any.
- E.** Keep electrical wiring, including all terminals and pressure connectors in good condition. Replace any wiring that has cracked, cut abraded or otherwise degraded insulation, or terminals that are worn, discolored or corroded. Keep all terminals and pressure connectors clean and tight.
- F.** Keep grounded and/or conductive objects such as tools away from exposed live electrical parts such as terminals to avoid arcing which might serve as a source of ignition.
- G.** Remove any acoustical material or other material that may be damaged by heat or that may support combustion and is in close proximity, prior to attempting weld repairs.
- H.** Keep suitable fully charged fire extinguisher or extinguishers nearby when servicing and operating the compressor.
- I.** Keep oily rags, trash, leaves, litter or other combustibles out of and away from the compressor.
- J. DO NOT** operate the compressor without proper flow of cooling air or water or with inadequate flow of lubricant or with degraded lubricant.

**K. DO NOT** attempt to operate the compressor in any classification of hazardous environment unless the compressor has been specially designed and manufactured for that duty.

## 1.5 MOVING PARTS

- A.** Keep hands, arms and other parts of the body and also clothing away from couplings, fans and other moving parts.
- B. DO NOT** attempt to operate the compressor with the fan, coupling or other guards removed.
- C.** Wear snug-fitting clothing and confine long hair when working around this compressor, especially when exposed to hot or moving parts.
- D.** Keep access doors, if any, closed except when making repairs or adjustments.
- E.** Make sure all personnel are out of and/or clear of the compressor prior to attempting to start or operate it.
- F.** Disconnect and lock out all power at source and verify at the compressor that all circuits are de-energized to minimize the possibility of accidental start-up or operation, prior to attempting repairs or adjustments. This is especially important when compressors are remotely controlled.
- G.** Keep hands, feet, floors, controls and walking surfaces clean and free of fluid, water, or other liquids to minimize the possibility of slips and falls.

## 1.6 HOT SURFACES, SHARP EDGES AND SHARP CORNERS

- A.** Avoid bodily contact with hot fluid, hot coolant, hot surfaces and sharp edges and corners.
- B.** Keep all parts of the body away from all points of air discharge.
- C.** Wear personal protective equipment including gloves and head covering when working in, on or around the compressor.
- D.** Keep a first aid kit handy. Seek medical assistance promptly in case of injury. **DO NOT** ignore small cuts and burns as they may lead to infection.

## 1.7 TOXIC AND IRRITATING SUBSTANCES

- A. DO NOT** use air from this compressor for respiration (breathing) except in full compliance with any Federal, State or Local Codes or regulations.

### **⚠ DANGER**

Death or serious injury can result from inhaling compressed air without using proper safety equipment.

- B. DO NOT** use air line anti-icer systems in air lines supplying respirators or other breathing air utilization equipment and **DO NOT** discharge air from these systems in unventilated or other confined areas.

**C.** Operate the compressor only in open or adequately ventilated areas.

**D.** Locate the compressor or provide a remote inlet so that it is not likely to ingest exhaust fumes or other toxic, noxious or corrosive fumes or substances.

**E.** Coolants and lubricants used in this compressor are typical of the industry. Care should be taken to avoid accidental ingestion and/or skin contact. In the event of ingestion, seek medical treatment promptly. Wash with soap and water in the event of skin contact. Consult the compressor operator's manual lubrication section for information pertaining to compressor fluid fill.

**F.** Wear goggles or a full face shield when adding antifreeze compound to air line anti-icer systems.

**G.** If air line anti-icer system antifreeze compound enters the eyes or if fumes irritate the eyes, they should be washed with large quantities of clean water for 15 minutes. A physician, preferably an eye specialist, should be contacted immediately.

**H. DO NOT** store air line anti-icer system antifreeze compound in confined areas.

**I.** The antifreeze compound used in air line anti-freeze systems contains methanol and is toxic, harmful, or fatal if swallowed. Avoid contact with the skin or eyes and avoid breathing the fumes. If swallowed, induce vomiting by administering a tablespoon of salt, in each glass of clean, warm water until vomit is clear, then administer two teaspoons of baking soda in a glass of clean water. Have patient lay down and cover eyes to exclude light. Call a physician immediately.

## 1.8 ELECTRICAL SHOCK

**A.** This compressor should be installed and maintained in full compliance with all applicable Federal, State and Local codes, standards and regulations, including those of the National Electrical Code, and also including those relative to equipment grounding conductors, and only by personnel that are trained, qualified and delegated to do so.

**B.** Keep all parts of the body and any hand-held tools or other conductive objects away from exposed live parts of electrical system. Maintain dry footing, stand on insulating surfaces and **DO NOT** contact any other portion of the compressor when making adjustments or repairs to exposed live parts of the electrical system. Make all such adjustments or repairs with one hand only, so as to minimize the possibility of creating a current path through the heart.

**C.** Attempt repairs in clean, dry and well lighted and ventilated areas only.

**D. DO NOT** leave the compressor unattended with open electrical enclosures. If necessary to do so, then disconnect, lock out and tag all power at source so others will not inadvertently restore power.

**E.** Disconnect, lock out, and tag all power at source prior to attempting repairs or adjustments to rotating machinery and prior to handling any ungrounded conductors.

**F.** Dry test all shutdown circuits prior to starting the compressor after installation.

## 1.9 LIFTING

**A.** If the compressor is provided with a lifting bail, then lift by the bail provided. If no bail is provided, then lift by sling. Compressors to be air lifted by helicopter must not be supported by the lifting bail but by slings instead. In any event, lift and/or handle only in full compliance with Federal, State and Local codes.

**B.** Inspect points of attachment for cracked welds and for cracked, bent, corroded or otherwise degraded members and for loose bolts or nuts prior to lifting.

**C.** Make sure entire lifting, rigging and supporting structure has been inspected, is in good condition and has a rated capacity of at least the weight of the compressor. If you are unsure of the weight, then weigh compressor before lifting.

**D.** Make sure lifting hook has a functional safety latch or equivalent, and is fully engaged and latched on the bail or slings.

**E.** Use guide ropes or equivalent to prevent twisting or swinging of the compressor once it has been lifted clear of the ground.

**F. DO NOT** attempt to lift in high winds.

**G.** Keep all personnel out from under and away from the compressor whenever it is suspended.

**H.** Lift compressor no higher than necessary.

**I.** Keep lift operator in constant attendance whenever compressor is suspended.

**J.** Set compressor down only on a level surface capable of safely supporting at least its weight and its loading unit.

**K.** When moving compressors by forklift truck, utilize fork pockets if provided. Otherwise, utilize pallet if provided. If neither fork pockets or pallet are provided, then make sure compressor is secure and well balanced on forks before attempting to raise or transport it any significant distance.

**L.** Make sure forklift truck forks are fully engaged and tipped back prior to lifting or transporting the compressor.

**M.** Forklift no higher than necessary to clear obstacles at floor level and transport and corner at minimum practical speeds.

**N.** Make sure pallet-mounted compressors are firmly bolted or otherwise secured to the pallet prior to attempting to forklift or transport them. **NEVER** attempt to forklift a compressor that is not secured to its pallet, as uneven floors or sudden stops may cause the compressor to tumble off, possibly causing serious injury or property damage in the process.

## Section 1

# SAFETY

**O. DO NOT** use the lifting eye bolt on the compressor motor, if supplied, to lift the entire compressor package.

### 1.10 ENTRAPMENT

**A.** If the compressor enclosure is large enough to hold a person and if it is necessary to enter it to perform service adjustments, inform other personnel

before doing so, or else secure and tag the access door in the open position to avoid the possibility of others closing and possibly latching the door with personnel inside.

**B.** Make sure all personnel are out of compressor before closing and latching enclosure doors.

## 2.1 INTRODUCTION

Your new Sullair flood-lubricated rotary screw air compressor will provide you with a unique experience in improved reliability and greatly reduced maintenance.

Compared to other types of compressors, the Sullair rotary screw is unique in mechanical reliability, with “no wear” and “no inspection” required of the working parts within the compressor unit.

Read Section 7 (Maintenance) to see how surprisingly easy it is to keep your air compressor in top operating condition.

## 2.2 DESCRIPTION OF COMPONENTS

Refer to Figures 2-1 and 2-2. The components and assemblies of the air compressor are clearly shown. The complete package includes **compressor, electric motor, starter, compressor inlet system, compressor discharge system, compressor lubrication and cooling system, capacity control system, instrument panel, aftercooler, a combination separator and trap**, all mounted on a heavy gauge steel frame.

On air-cooled models, a fan draws air over the motor and forces it out through the combined aftercooler and fluid cooler thereby removing the compression heat from the compressed air and the cooling

fluid.

On water-cooled models, a shell and tube heat exchanger is mounted on the compressor frame. Fluid is piped into the heat exchanger where compression heat is removed from the fluid. Another similar heat exchanger cools the compressed air.

Both air-cooled and water-cooled versions have easily accessible items such as the fluid filters and control valves. The inlet air filter is also easily accessible for servicing.

## 2.3 SULLAIR COMPRESSOR UNIT, FUNCTIONAL DESCRIPTION

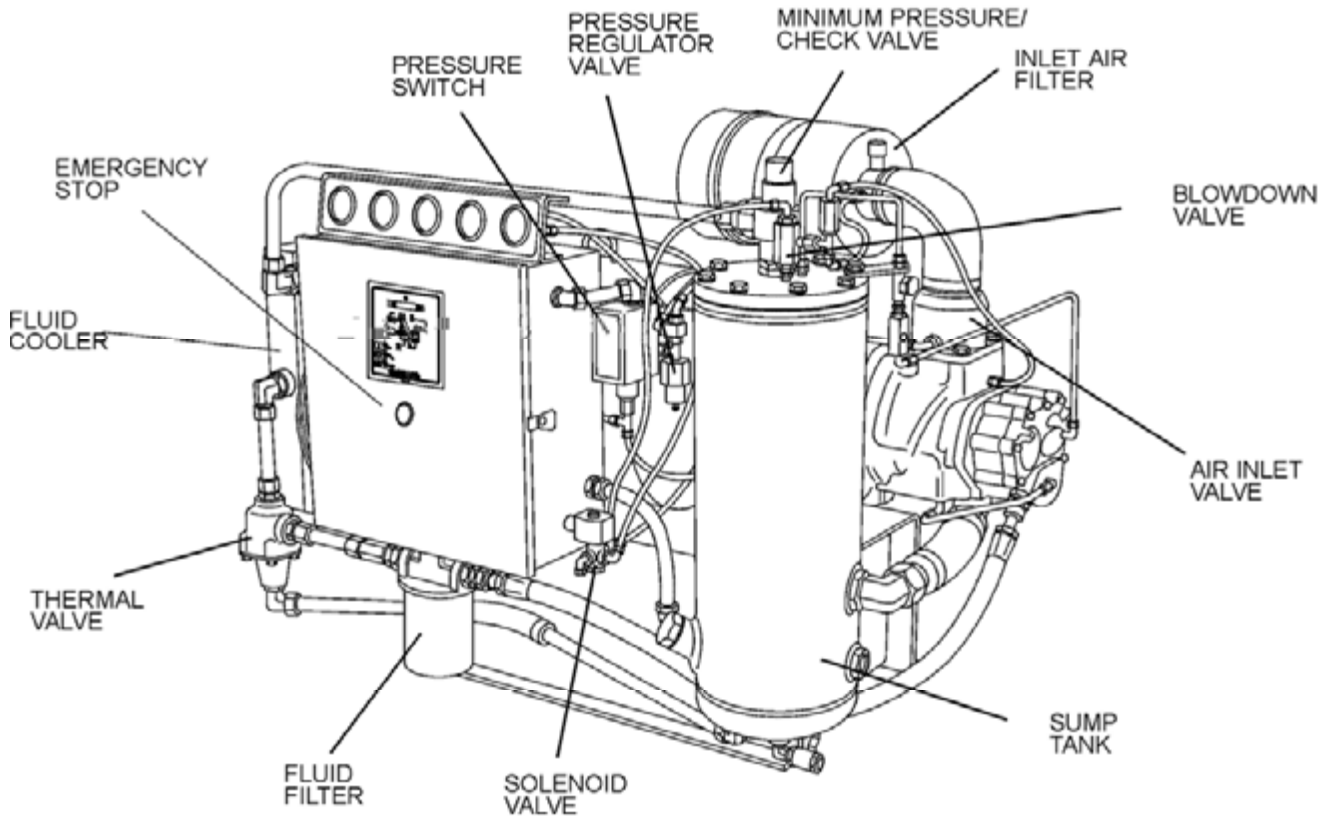
Sullair air compressors feature the Sullair compressor unit, a single-stage, positive displacement, flood lubricated-type compressor. This unit provides continuous compression to meet your needs.

### NOTE

With a Sullair compressor, there is no maintenance or inspection of the internal parts of the compressor unit permitted in accordance with the terms of the warranty.

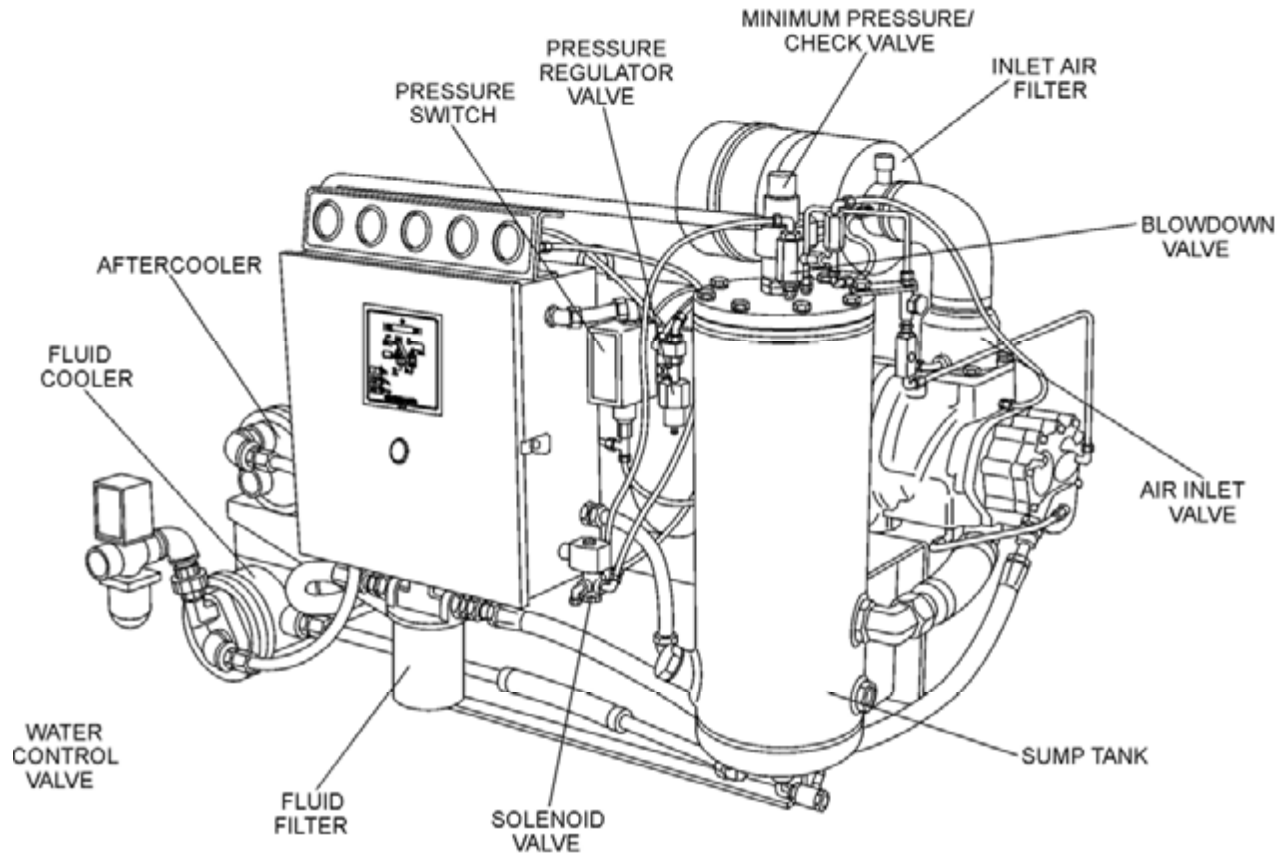
Sullair 24KT compressors are filled with a fluid which rarely needs to be changed. In the event a

*Figure 2-1 Sullair Rotary Screw Air Compressor- Air-cooled Model*



## Section 2 DESCRIPTION

Figure 2-2 Sullair Rotary Screw Air Compressor- Water-cooled Model



change of fluid is required, use only Sullair 24KT fluid.

### ▲ WARNING

**Mixing of other lubricants within the compressor unit will void all warranties!**

Sullair recommends that a 24KT sample be taken at the first filter change and sent to the factory for analysis. This is a free service. The sample kit with instructions and self-addressed container is to be supplied by your Sullair dealer at start-up. The user will receive an analysis report with recommendations.

Fluid is injected into the compressor unit in large quantities and mixes directly with the air as the rotors turn, compressing the air. The fluid flow has three basic functions:

1. As coolant, it controls the rise of air temperature normally associated with the heat of compression.
2. Seals the leakage paths between the rotors and the stator and also between the rotors them-

selves.

3. Acts as a lubricating film between the rotors allowing one rotor to directly drive the other, which is an idler.

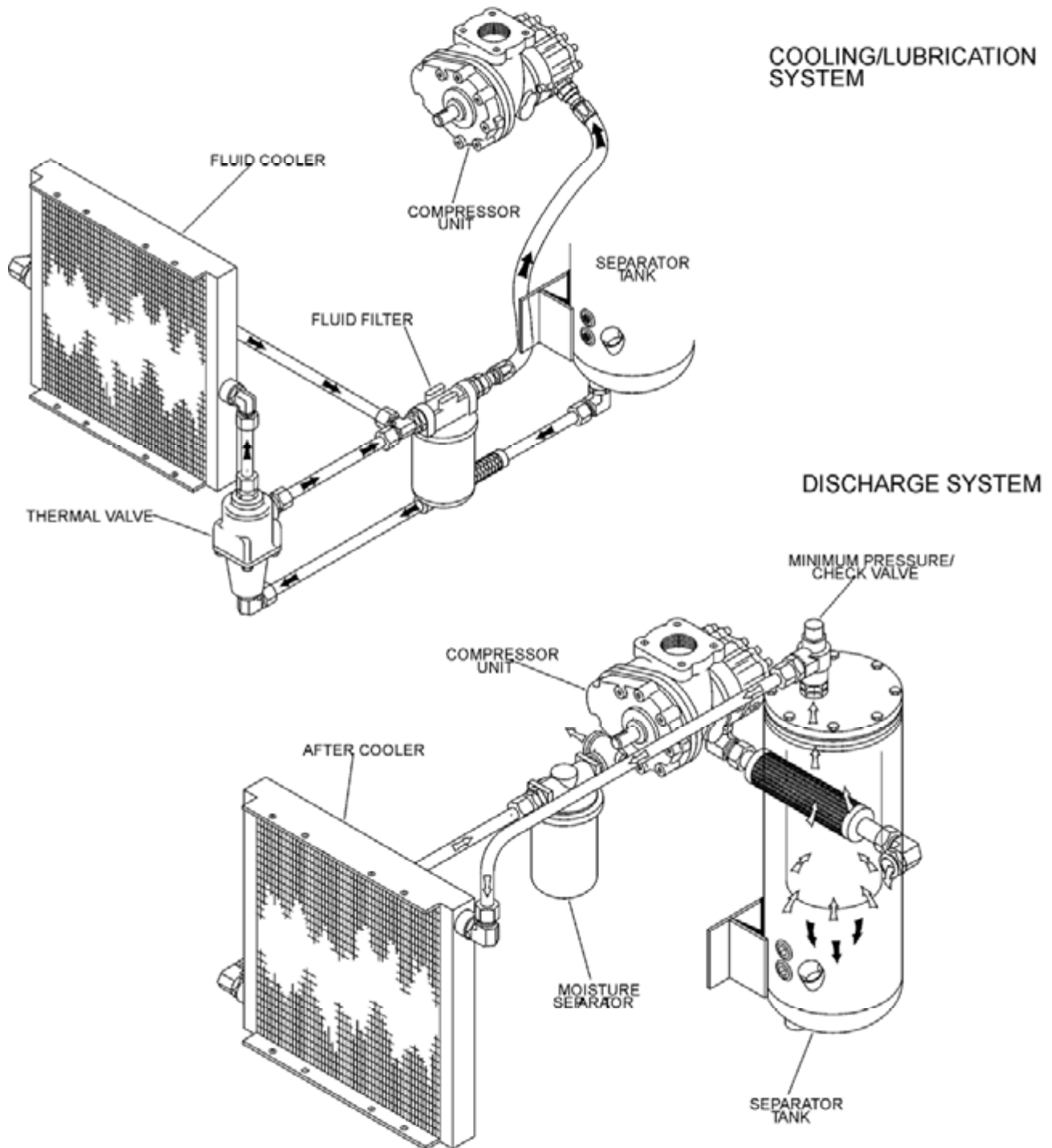
After the air/fluid mixture is discharged from the compressor unit, the fluid is separated from the air. At this time, the air flows through an aftercooler and separator then to your service line while the fluid is being cooled in preparation for reinjection.

### 2.4 COMPRESSOR COOLING AND LUBRICATION SYSTEM, FUNCTIONAL DESCRIPTION

Refer to Figures 2-3A and 2-3B. The Cooling and Lubrication System (air-cooled version) consists of a fan, double shaft drive motor, radiator-type aftercooler and fluid cooler, full flow fluid filter, thermal valve, and interconnecting piping and tubing. For water-cooled models, two shell and tube heat exchangers and a water-flow regulating valve are substituted for the radiator-type cooler listed above.

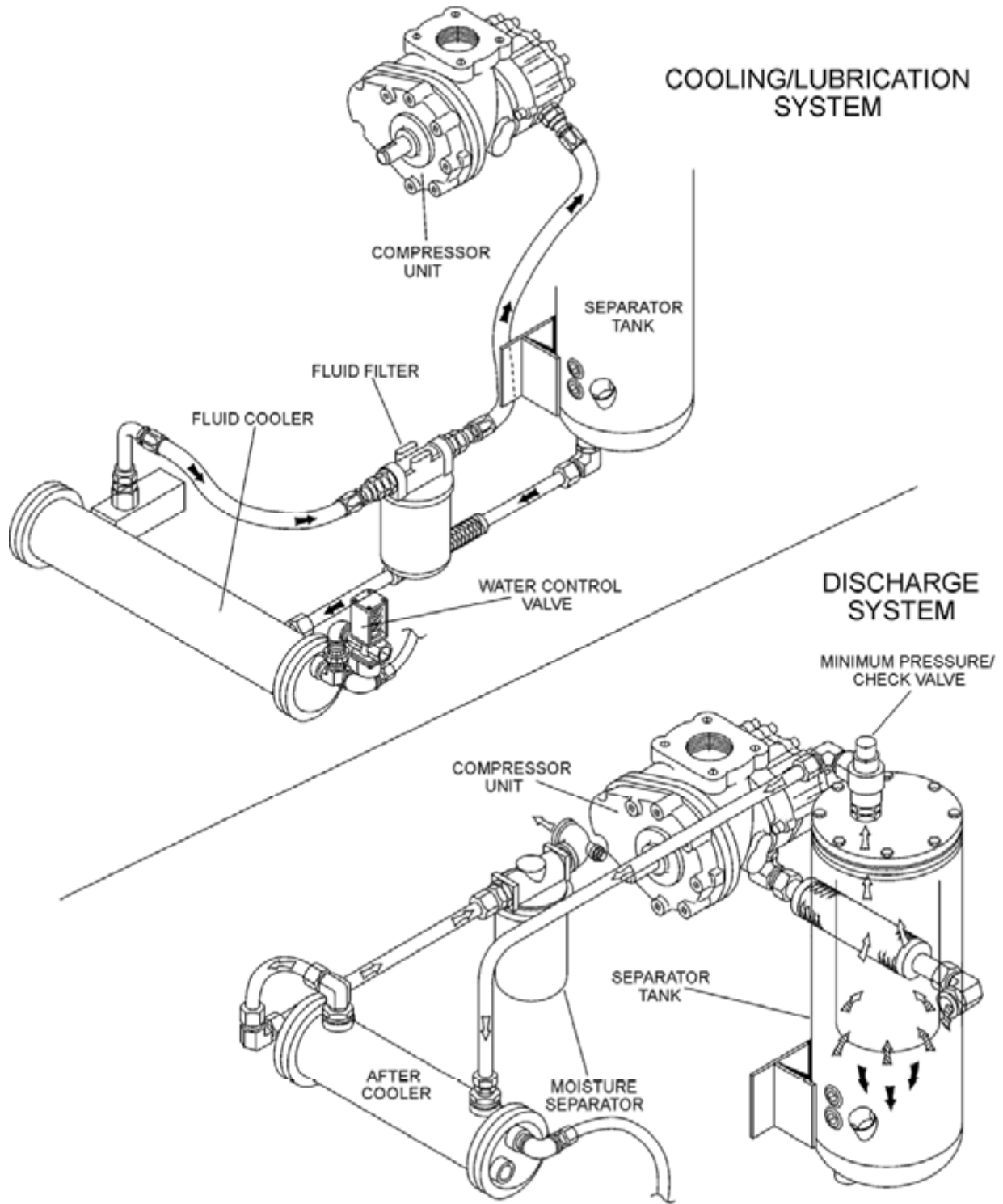
The pressure in the receiver/sump causes fluid flow by forcing the fluid from the high pressure area of the sump to an area of lower pressure in the compressor unit.

*Figure 2-3A Compressor Fluid Cooling/Lubrication and Discharge System- Air-cooled Model*



Section 2  
**DESCRIPTION**

*Figure 2-3B Compressor Fluid Cooling/Lubrication and Discharge System- Water-cooled Model*



Fluid flows from the bottom of the receiver/sump to the thermal valve. The thermal valve is fully open when the fluid temperature is below 170\_F (77\_C). The fluid passes through the thermal valve, the main filter and directly to the compressor unit where it lubricates, cools and seals the rotors and the compression chamber.

As the discharge temperature rises above 170\_F (77\_C), due to the heat of compression, the thermal valve begins to close and a portion of the fluid then flows through the cooler. From the cooler the fluid flows to the main filter and then on to the compressor unit.

A portion of the fluid flowing to the compressor is routed to the anti-friction bearings which support the rotors inside the compressor unit. Prior to entering the compressor unit, this fluid is taken through the fluid filter, thus assuring properly filtered lubricant for bearing supply.

The fluid filter has a replacement element and an integral pressure bypass valve. A gauge on the instrument panel shows red when the filter needs servicing. This gauge has a pressure setting lower than that of the bypass valve. The gauge should be checked with compressor running at full system pressure.

Water-cooled versions of the compressor have a water-flow regulating valve (not shown) which operates to conserve water during periods of varying load on the compressor. This same valve automatically shuts off the water supply when the compressor is shut down. In addition, water-cooled models have a water pressure switch to prevent operation with inadequate water pressure.

### 2.5 COMPRESSOR DISCHARGE SYSTEM, FUNCTIONAL DESCRIPTION

Refer to Figures 2-3A and 2-3B. The compressor unit discharges the compressed air/fluid mixture into the combination receiver/sump.

The receiver has three basic functions:

1. It acts as a primary fluid separator.
2. Serves as the compressor fluid sump.
3. Houses the final fluid separator.

The compressed air/fluid mixture enters the receiver and is directed against the internal baffle. The direction of movement is changed and its velocity significantly reduced, thus causing large droplets of fluid to form and fall to the bottom of the receiver/sump. The fractional percentage of fluid remaining in the compressed air collects on the surface of the separator element as the compressed air flows through the separator. A return line (or scavenge tube) leads from the bottom of the separator element to the inlet region of the compressor unit. Fluid collecting on the bottom of the separator is returned to the compressor by a pressure differential between the receiver and the compressor inlet. A visu-

al sight glass is located on the return line to observe this fluid flow. There is also an orifice in this return line (protected by a strainer) to assure proper flow. This separation will reduce the fluid carry-over to less than 2 ppm (parts per million). A gauge, located on the instrument panel, shows red if abnormal pressure drop through the separator develops. At this time, separator element replacement is necessary. This gauge must be checked with the compressor running fully loaded.

A minimum pressure/check valve, located downstream from the separator, assures a minimum receiver pressure of 55 psig (3.8 bar) during loaded conditions. This pressure is necessary for proper air/fluid separation and proper fluid circulation.

A terminal check valve is incorporated into the minimum pressure/check valve to prevent compressed air in the service line from bleeding back into the receiver on shutdown and during operation of the compressor in an unloaded condition.

A pressure relief valve (located on the wet side of the separator) is set to open if the sump pressure exceeds the sump tank rating. A temperature switch will shut down the compressor if the discharge temperature reaches 235\_F (113\_C).

#### **▲ WARNING**

**DO NOT remove caps, plugs, and/or other components when compressor is running or pressurized.**

**Stop compressor and relieve all internal pressure before doing so.**

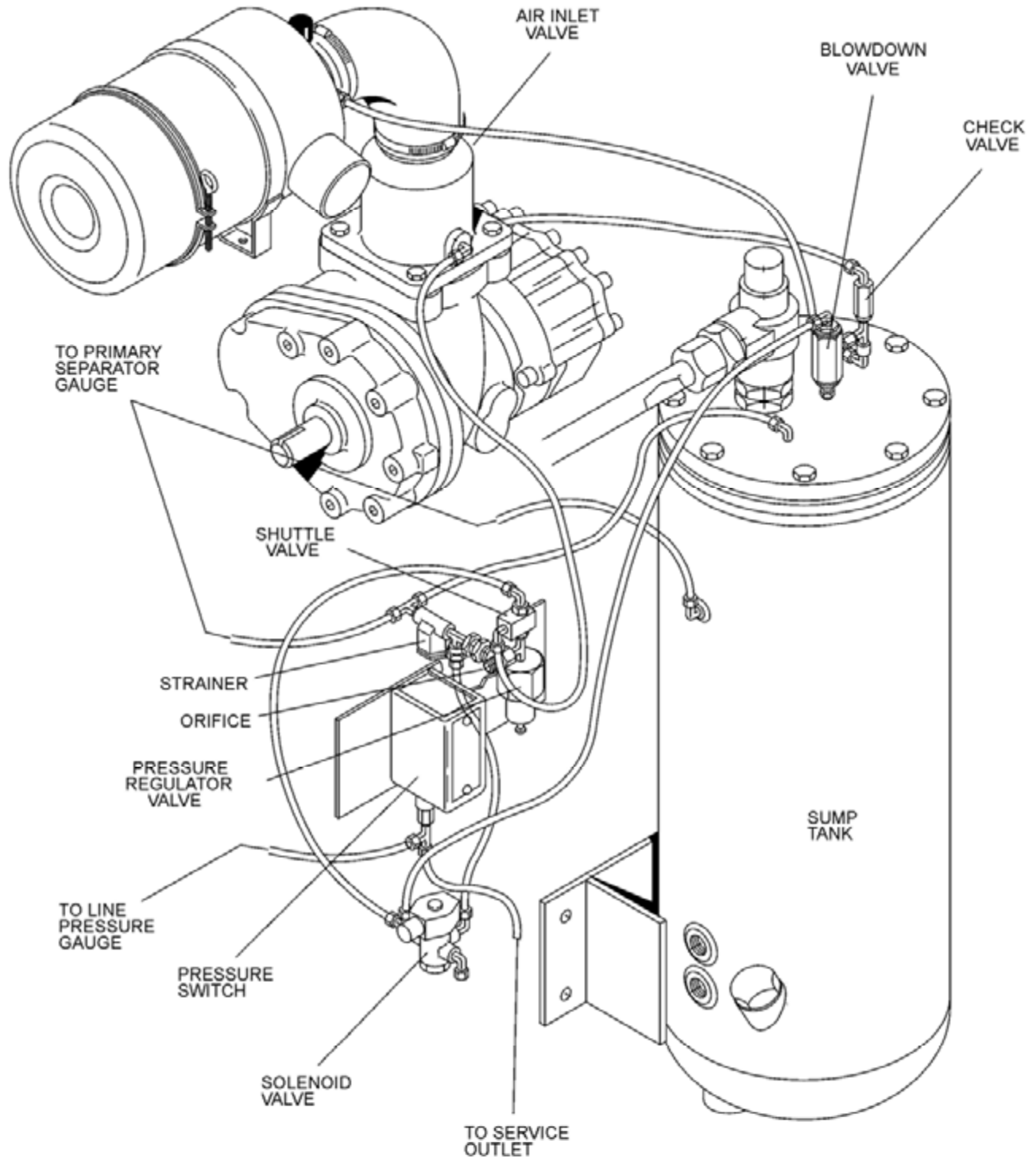
Fluid is added to the sump via a capped fluid filler opening, placed low on the tank to prevent overflowing of the sump. A sight glass enables the operator to visually monitor the sump fluid level.

### 2.6 CONTROL SYSTEM, FUNCTIONAL DESCRIPTION- STANDARD ELECTRO-MECHANICAL

Refer to Figure 2-4. The purpose of the compressor Control System is to regulate the compressor air intake to match the amount of compressed air being used. At approximately 10 psig (0.7 bar) air line over-pressure, the control system will automatically blow down the compressor and greatly reduce the unload power consumption. The Control System consists of an **inlet valve**, (located on the compressor air inlet), **blowdown valve**, **solenoid valve**, **pressure switch**, and a **pressure regulator**. The functional descriptions of the Control System are given below in four distinct phases of compressor operation. The following guidelines apply to all LS-10 Series compressors. For explanatory purposes this description will apply to a compressor with an operating pressure range of 115 to 125 psig (7.9 to 8.6 bar). A compressor with any other pressure range would operate in the same manner ex-

# Section 2 DESCRIPTION

Figure 2-4 Control System



cepting stated pressures.

### **START - 0 TO 50 PSIG (0 TO 3.5 BAR)**

When the compressor START button is depressed, the sump pressure will quickly rise from 0 to 50 psig (0 to 3.5 bar). During this period both the pressure regulator and the solenoid valve are closed, the inlet valve is fully open due to inlet air flow, and the compressor pumps at full rated capacity. The rising compressor air pressure is isolated from the service line in this phase by the minimum pressure valve, set at approximately 50 psig (3.5 bar).

### **NORMAL OPERATING MODE - 50 TO 115 PSIG (3.5 TO 7.9 BAR)**

When the pressure air rises above 50 psig (3.5 bar), the minimum pressure/check valve opens and delivers compressed air to the service line. From this point on, the line air pressure is continually monitored by a line pressure gauge and a pressure switch usually set at 125 psig (8.6 bar). The pressure regulator and the solenoid valve remain closed during this phase. The inlet valve remains fully open for maximum capacity.

### **MODULATING MODE - 115 TO 125 PSIG (7.9 TO 8.6 BAR)**

If less than the rated capacity of compressed air is being used, the service line pressure will rise above 115 psig (7.9 bar). The pressure regulator valve gradually opens, applying air pressure through the control line to the inlet valve piston. This causes the inlet valve to partially close reducing the amount of air entering the compressor until it matches the amount of air being used. The control system functions continually in this manner, between the limits of 115 to 125 psig (7.9 to 8.6 bar), in response to varying demands from the service line.

The pressure regulator has an orifice which vents a small amount of air to the atmosphere when the pressure regulator controls the inlet valve. The orifice also bleeds any accumulated moisture from the control lines.

### **UNLOAD - IN EXCESS OF 125 PSIG (8.6 BAR) LINE PRESSURE**

When no air is being used, the service line pressure rises to the setting (cut-out pressure) of the pressure switch. The pressure switch opens, interrupting the electrical power to the solenoid valve. At this time, the solenoid valve allows dry sump tank air pressure or service air pressure through a shuttle valve to be applied directly to the inlet valve piston and keep it closed. Simultaneously, the solenoid valve sends a pneumatic signal to the blowdown valve. The blowdown valve opens the sump to the compressor intake reducing the sump pressure to approximately 25 to 27 psig (1.7 to 1.9 bar). The check valve in the air service line pressure prevents line pressure from returning to the sump.

When the line pressure drops to the low setting (cut-in pressure) of the pressure switch (usually 115 psig

[7.9 bar]), the pressure switch closes, re-energizing the 3-way solenoid valve and allowing the blowdown valve to close. The re-energized solenoid valve again prevents pressure from reaching the inlet valve. The inlet valve is fully open and the compressor delivers full rated capacity. Should the pressure begin to rise, the pressure regulator will resume its normal function as previously described.

To accommodate varied periods of time when there are not any air requirements, "Dual-Control" is utilized. This feature allows you to set the compressor in an automatic position whereby the compressor will shut down when no compressed air requirement is present and restart as compressed air is needed.

## **2.7 CONTROL SYSTEM, FUNCTIONAL DESCRIPTION- SUPERVISOR II**

Refer to Figure 2-4. The purpose of the compressor Control System is to regulate the amount of air being compressed to match the amount of compressed air being used. The Capacity control system consists of a **solenoid valve, regulator valve and an inlet valve**. The functional description of the Control System is described below in four distinct phases of operation. The following description text applies to all LS-10 Series compressors with optional Supervisor II. For explanatory purposes, this description will apply to a compressor with an operating range of 100 to 110 psig (6.9 to 7.6 bar). A compressor with any other pressure range would operate in the same manner except stated pressures.

### **START MODE - 0 TO 50 PSIG (0 TO 3.5 BAR)**

When the compressor "I" (START) pad is depressed, the sump pressure will quickly rise from 0 to 50 psig (0 - 3.4 bar). The compressor initially starts unloaded, then switches to full load when full rpm has been achieved. During this period, both the pressure regulator and the solenoid valve are closed, the inlet valve is fully open and the compressor pumps at full rated capacity. The rising compressor air pressure is isolated from the service line in this phase by the minimum pressure valve set at approximately 50 psig (3.4 bar).

### **FULL LOAD MODE - 50 TO 100 PSIG (3.4 TO 6.9 BAR)**

When the compressed air pressure rises above 50 psig (3.4 bar), the minimum pressure valve opens allowing compressed air to flow into the service line. From this point on, the line air pressure is continually monitored by the Supervisor. The pressure regulator and the solenoid valve remain closed during this phase. The inlet valve is in the fully open position as long as the compressor is running at 100 psig (6.9 bar) or below.

### **MODULATING MODE - 100 TO 110 PSIG (6.9 TO 7.6 BAR)**

If less than the rated capacity of compressed air is being used, the service line pressure will rise above 100 psig (6.9 bar). The pressure regulator valve gradually opens, directing air pressure to the inlet

## Section 2

# DESCRIPTION

control valve, reducing air entering the compressor until it matches the amount of air being used. The control system functions continually in this manner between the limits of 100 to 110 psig (6.9 to 7.6 bar) in response to varying demands from the service line.

The pressure regulator has an orifice which vents a small amount of air to the atmosphere when the pressure regulator controls the inlet control valve. The orifice also bleeds any accumulated moisture from the pressure regulator.

### UNLOAD MODE - IN EXCESS OF 110 PSIG (7.6 BAR)

When a relatively small amount or no air is being used, the service line pressure continues to rise. When it exceeds 110 psig (7.6 bar), the Supervisor Control System de-energizes the solenoid valve allowing sump air pressure to be supplied directly to close the inlet valve. Simultaneously, the solenoid valve sends a pneumatic signal to the blowdown valve. The blowdown valve opens to the atmosphere, reducing the sump pressure to approximately 25 to 27 psig (1.7 to 1.9 bar). The check valve in the air service line prevents line pressure from returning to the sump.

When the line pressure drops to the low setting (cut-in pressure; usually 100 psig [6.9 bar] on low pressure ["L"] compressors and 115 psig [8.0 bar] on high pressure ["H"] compressors, 140 psig [9.7 bar] on ["HH"] compressors, 175 psig [12.0 bar] ["XH"] . Supervisor energizes the solenoid valve and allows the blowdown valve to close. The re-energized solenoid valve again prevents line pressure from reaching the inlet control valve. Should the pressure begin to rise, the pressure regulator will resume its normal function as previously described.

### AUTOMATIC OPERATION

For applications with varied periods of time when there are no air requirements, Supervisor's AUTOMATIC mode allows the compressor to shutdown (time delayed) when no compressed air requirement is present and restart as compressed air is needed.

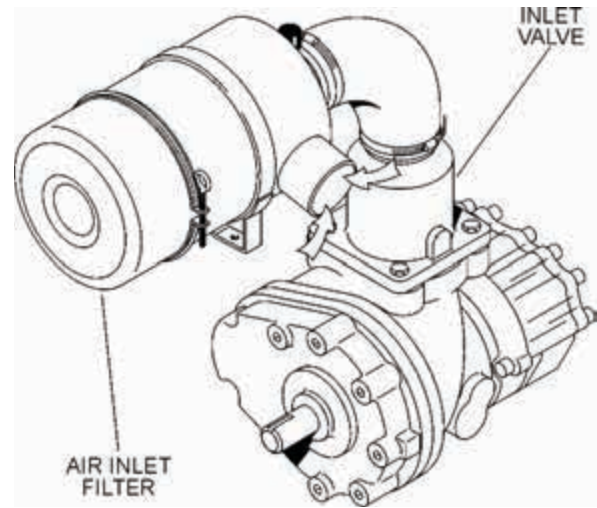
## 2.8 AIR INLET SYSTEM, FUNCTIONAL DESCRIPTION

Refer to Figure 2-5. The Compressor Inlet System consists of a **dry-type air filter**, a **restriction gauge** and an **air inlet valve**.

The restriction gauge (located on the instrument panel), indicates the condition of the air filter by showing red when filter maintenance is required.

The poppet-type modulating air inlet valve directly controls the amount of air intake to the compressor in response to the operation of the pressure regulator (see Modulating Mode, Section 2.6 [Standard Elector/Mechanical] or Section 2.7 [Optional Supervisor II]). The inlet valve also acts as a check valve, thus preventing reverse rotation when the

Figure 2-5 Air Inlet System



compressor is shut down.

### ▲ WARNING

"The Plastic Pipe Institute recommends against the use of thermoplastic pipe to transport compressed air or other compressed gases in exposed above ground locations, e.g. in exposed plant piping." (I)

Sullube should not be used with PVC piping systems. It may affect the bond at cemented joints. Certain other plastic materials may also be affected.

(I) Plastic Pipe Institute, Recommendation B, Adopted January 19, 1972.

## 2.9 INSTRUMENT PANEL GROUP, FUNCTIONAL DESCRIPTION- STANDARD ELECTRO-MECHANICAL CONTROLLER

The electro-mechanical controller responds to signals from traditional pressure switch sensors and provides **stop/start**, **common fault indication**, **sensor bypass timing**, **wye-delta transition timing**, and facilitates selectable **automatic restart** after power failure. Two-wire remote Stop/Start input is provided.

Refer to Figure 2-6 for specific location of parts described.

§ The **sump pressure gauge** continually monitors the sump pressure at the various load and/or unload conditions.

§ The **discharge temperature gauge** monitors the temperature of the air leaving the compressor unit. For both air-cooled and water-cooled compressors the normal reading is approximately 180\_F to 205\_F (82\_C to 96\_C).

§ The **separator maintenance gauge** monitors condition of the separator element and shows in the

red zone when the element restriction is excessive.


§ The **fluid filter maintenance gauge** monitors the condition of the bearing lube filter element and shows in the red zone when the element should be changed.

§ The **START (I)** pad turns the compressor on.


§ The **STOP (O)** pad turns the compressor off.

§ The **hourmeter** records accumulative hours of operation for the compressor and is useful for planning

and logging service operations.

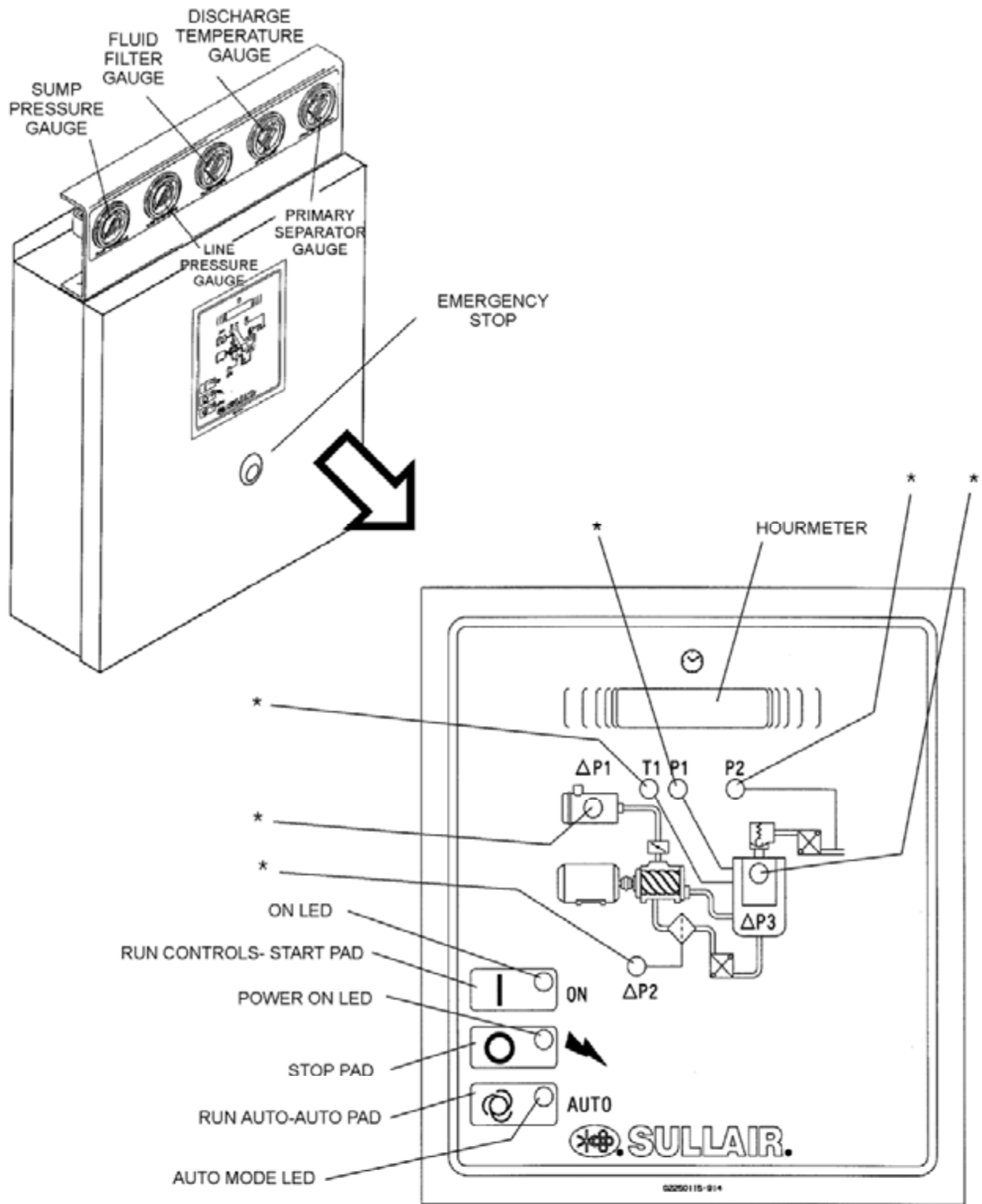
§ The **POWER ON** (  ) LED on the instrument panel indicates when power to the compressor is supplied.

§ The **ON** LED indicates when the compressor is running.

§ The **AUTO** (  ) pad is used to enable automatic control.

# Section 2 DESCRIPTION

Figure 2-6 Instrument Panel Group and Controller Panel (Electro-Mechanical)



# Section 3 SPECIFICATIONS

## 3.1 TABLE OF SPECIFICATIONS

<b>LS-10 SERIES 60 Hz</b>							
<b>MODEL</b>	<b>HP/KW</b>	<b>CAPACITY (ACFM/M<sup>3</sup>/MIN)</b>	<b>LENGTH (I) (IN/MM)</b>	<b>WIDTH (IN/MM)</b>	<b>HEIGHT(II) (IN/MM)</b>	<b>WEIGHT (LB/KG)</b>	<b>MOTOR ENCLOSURE</b>
<b>H</b> (115 psig/ 8 bar)	25/18	102/2.89	57.0/1448	33.3/846	39.0/991	1015/2238	ODP/TEFC
	30/22	113/3.20	57.0/1448	33.3/846	39.0/991	1015/2238	ODP/TEFC
	40/30	152/4.30	57.0/1448	33.3/846	39.0/991	1140/2513	ODP
	40/30	151/4.28	62.5/1588	33.3/846	39.0/991	1165/2568	TEFC
<b>HH</b> (140 psig/ 19.7 bar)	25/18	83/2.35	57.0/1448	33.3/846	39.0/991	1015/2238	ODP/TEFC
	30/22	100/2.83	57.0/1448	33.3/846	39.0/991	1015/2238	ODP/TEFC
	40/30	142/4.02	57.0/1448	33.3/846	39.0/991	1140/2513	ODP
	40/30	142/4.02	62.5/1588	33.3/846	39.0/991	1165/2568	TEFC
<b>XH</b> (175 psig/ 12 bar)	25/18	76/2.15	57.0/1448	33.3/846	39.0/991	1015/2238	ODP/TEFC
	30/22	90/2.55	57.0/1448	33.3/846	39.0/991	1015/2238	ODP/TEFC
	40/30	119/3.37	57.0/1448	33.3/846	39.0/991	1140/2513	ODP
	40/30	119/3.37	62.5/1588	33.3/846	39.0/991	1165/2568	TEFC
<b>LS-10 SERIES 50 Hz</b>							
<b>MODEL</b>	<b>HP/KW</b>	<b>CAPACITY (ACFM/M<sup>3</sup>/MIN)</b>	<b>LENGTH (I) (IN/MM)</b>	<b>WIDTH (IN/MM)</b>	<b>HEIGHT(II) (IN/MM)</b>	<b>WEIGHT (LB/KG)</b>	<b>MOTOR ENCLOSURE</b>
<b>H</b> (115 psig/ 8 bar)	25/18	93/2.63	57.0/1448	33.3/846	39.0/991	1015/2238	ODP/TEFC
	30/22	118/3.34	57.0/1448	33.3/846	39.0/991	1015/2238	ODP/TEFC
	40/30	160/4.53	57.0/1448	33.3/846	39.0/991	1140/2513	ODP
	40/30	160/4.53	62.5/1588	33.3/846	39.0/991	1165/2568	TEFC
<b>HH</b> (140 psig/ 19.7 bar)	25/18	82/2.32	57.0/1448	33.3/846	39.0/991	1015/2238	ODP/TEFC
	30/22	99/2.80	57.0/1448	33.3/846	39.0/991	1015/2238	ODP/TEFC
	40/30	137/3.88	57.0/1448	33.3/846	39.0/991	1140/2513	ODP
	40/30	137/3.88	62.5/1588	33.3/846	39.0/991	1165/2568	TEFC
<b>XH</b> (175 psig/ 12 bar)	25/18	73/2.07	57.0/1448	33.3/846	39.0/991	1015/2238	ODP/TEFC
	30/22	90/2.55	57.0/1448	33.3/846	39.0/991	1015/2238	ODP/TEFC
	40/30	115/3.26	57.0/1448	33.3/846	39.0/991	1140/2513	ODP
	40/30	115/3.26	62.5/1588	33.3/846	39.0/991	1165/2568	TEFC
<b>ENCLOSURE</b>							
<b>25-30 HP/ 18-22 KW</b>	-	-	60.0/1524	36.0/914	42.0/1067	(III)	ODP/TEFC
<b>40 HP/30 KW (ODP)</b>	-	-	60.0/1524	36.0/914	42.0/1067	(III)	ODP
<b>40 HP/30 KW (TEFC)</b>	-	-	64.5/1638	36.0/914	42.0/1067	(III)	TEFC

(I) For water-cooled (open) model, add 1.5 in/ 38mm to length, and 1 in/ 25 mm to height.

(II) An additional length of 4 in./102mm is needed for servicing the separator; 9 in./229mm for enclosure models.

(III) Add 250 lbs/ 113.4 kgs for the enclosure to the total package weight.

## Section 3

# SPECIFICATIONS

### COMPRESSOR:

Type:  
Standard Operating Pressure (IV):

Bearing Type:  
Ambient Temperature (Max.) (V):  
Cooling:  
Compressor Fluid:  
Sump Capacity:  
Control:

### STANDARD MODELS

Rotary Screw  
100 psig (6.9bar) (L)                      140 psig (9.7 bar) (HH)  
115 psig (7.9bar) (H) (XH)              175 psig (12 bar) (XH)  
Anti-Friction  
105\_F (41\_C)  
Pressurized Fluid  
Sullair Sullube  
3.5 U.S. gallons (14.8 liters)  
Electro-Pneumatic  
Supervisor II (optional)

### MOTOR (VI):

Size:  
Type:

Starter:

Speed:

### STANDARD MODELS

25, 30 and 40HP  
C-Flanged, Open Dripproof, Premium Efficiency  
Three Phase, 230/460 60 Hz, 380/415 50 Hz  
40\_C Maximum Ambient Temperature  
Options Available: 200V and 575V  
T.E.F.C. Also Available: IP54  
Full Voltage Magnetic or Wye Delta  
Options Available: 200V and 575V  
60 Hz: 1770 RPM  
50 Hz: 1475 RPM  
40HP: 3000 RPM

(IV) Special compressors are available for operation at higher pressures.

(V) Special compressors are available for operation in higher ambient temperature.

(VI) Multi-frequency and voltage motors are used. The compressors must be used only with the specified electrical frequency and voltage.

## 3.2 LUBRICATION GUIDE

For best value and longest uninterrupted service, the LS-10 Series compressors are factory filled and tested with a long life lubricant.

### ⚠ WARNING

Mixing of other lubricants within the compressor unit will void all warranties!

If, due to availability or other reasons, other fluids are required, follow Lubrication Guide 3.4 below.

### ⚠ WARNING

“The Plastic Pipe Institute recommends against the use of thermoplastic pipe to transport compressed air or other compressed gases in exposed above ground locations, e.g. in exposed plant piping.” (I)

Sullube should not be used with PVC piping systems. It may affect the bond at cemented joints. Certain other plastic materials may also be affected.

(I) Plastic Pipe Institute, Recommendation B, Adopted January 19, 1972.

Maintenance of all other components is still recommended as indicated in the Operator’s Manual.

For light-duty high-humidity service where condensed moisture and emulsification (mayonnaise) may occur, the fluid change interval must be reduced to 300 hours maximum. A non-detergent fluid with rust, oxidation and foam inhibitors and good water separation characteristics should be used.

### DO NOT MIX DIFFERENT TYPES OF FLUIDS.

Contamination of non-detergent mineral fluids with traces of detergent motor fluids may lead to operational problems such as foaming, filter plugging, orifice or line plugging.

### NOTE

Flush system when switching lubricant brands.

When ambient conditions exceed those noted or if conditions warrant use of “extended” life lubricants contact Sullair for recommendation.

## 3.3 APPLICATION GUIDE

Sullair encourages the user to participate in a fluid analysis program with the fluid suppliers. This could result in a fluid change interval differing from that stated in the manual. Contact your Sullair dealer for details.

**3.4 LUBRICATION CHANGE RECOMMENDATIONS AND MAINTENANCE**

---

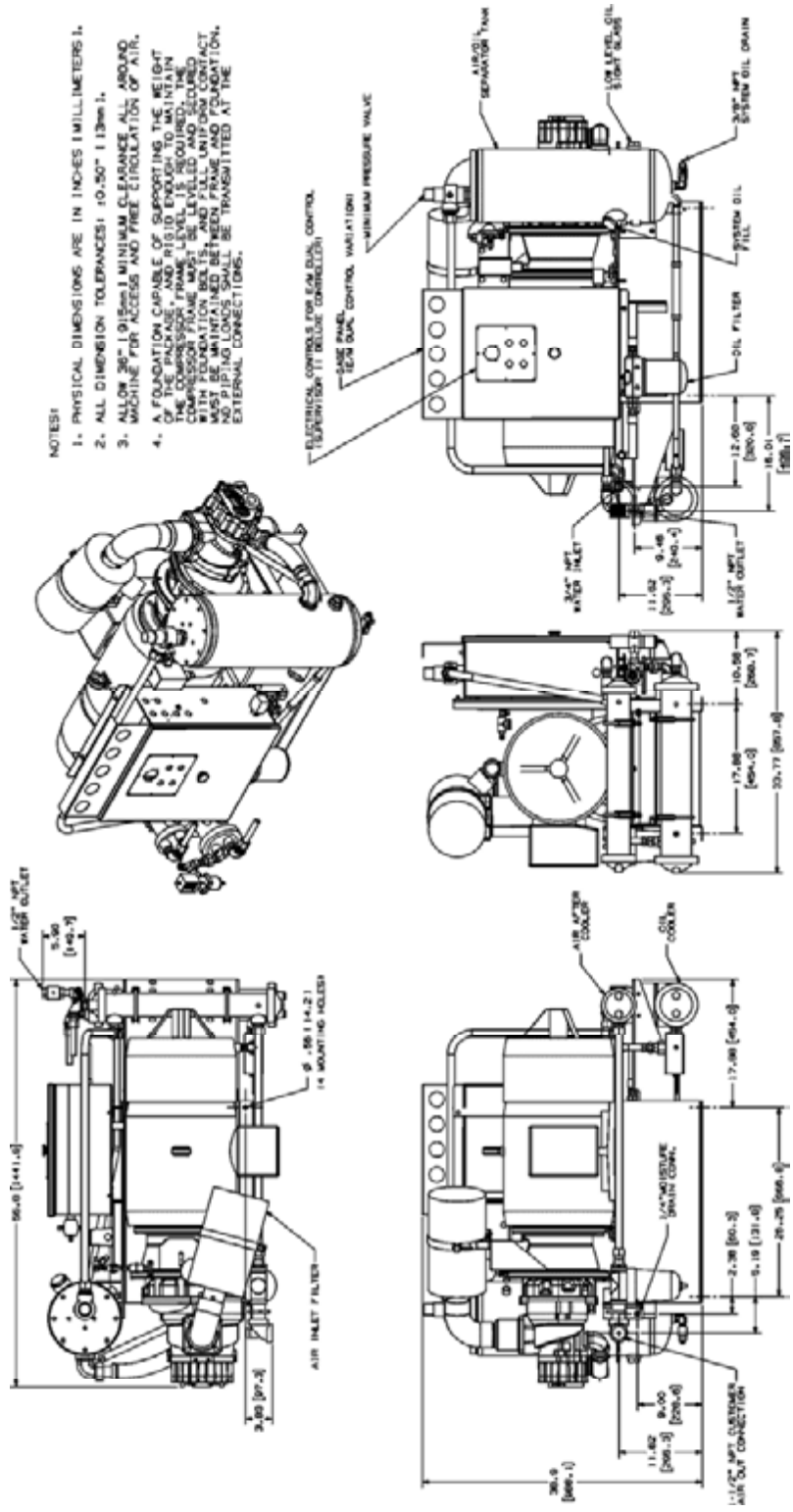
LUBRICANT	FLUID CHANGE	FLUID FILTER CHANGE	SEPARATOR CHANGE
Sullube	A, E	G, C	A, D
Sullair LLL-4-F	A, E	G, C	A, D
SRF 1/4000	B, E	G, C	B, D
24KT	F, E	G, C	A, D
Sullair CP-4600-32-F	B, E	G, C	B, D

---

- A** - 8,000 Hours or once a year.
  - B** - 4,000 Hours or more frequently if conditions so require.
  - C** - When measured pressure loss exceeds 20 psig (1.3 bar).
  - D** - When measured pressure loss exceeds 10 psig (0.7 bar).
  - E** - When required by fluid analysis or known contamination.
  - F** - Does not require replacement during normal service conditions.
  - G** - Every 1000 hours.
-

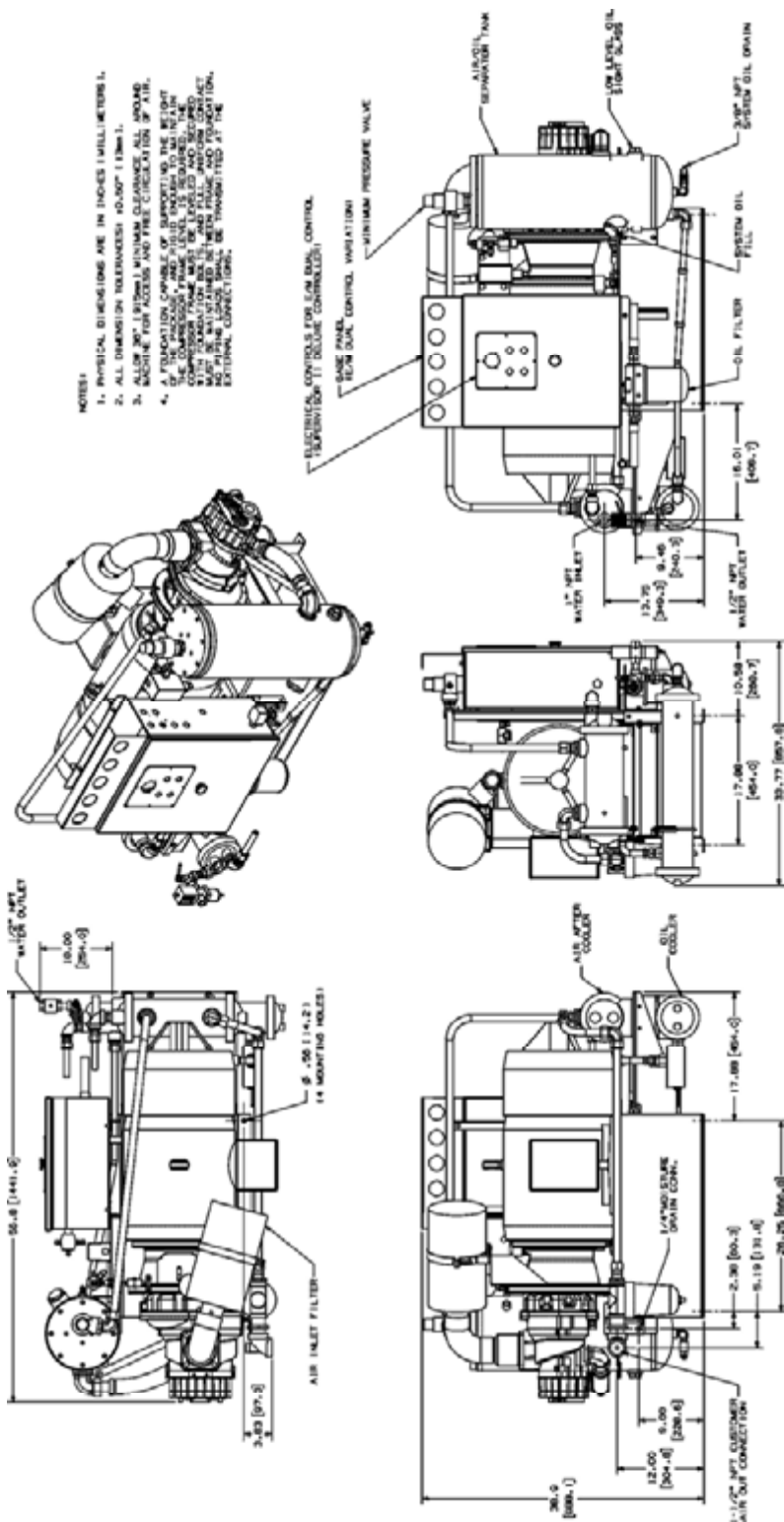


Figure 3-2 Identification- Water-cooled 25-30HP/ 18-22KW Models



# Section 3 SPECIFICATIONS

Figure 3-2 Identification- Water-cooled 40HP/ 30KW Model



**4.1 MOUNTING OF COMPRESSOR**

A foundation or mounting capable of supporting the weight of the compressor, and rigid enough to maintain the compressor frame level and the compressor in alignment is required. The compressor frame must be leveled and secured with foundation bolts, and full uniform contact must be maintained between the frame and foundation. No piping loads shall be transmitted to the compressor at the external connections.

**4.2 VENTILATION AND COOLING**

For air-cooled compressors, select a location to permit sufficient unobstructed air flowing in and out to the compressor to keep the operating temperature stable. The minimum distance that the compressor should be from surrounding walls is three (3) feet (1m). To prevent excessive ambient temperature rise, it is imperative to provide adequate ventilation.

For water-cooled compressors, it is necessary to check the cooling water supply. The water system must be capable of supplying the flows shown in Table 1-Water Supply Requirements (Water-cooled), and must be maintained at all times. These figures apply to a compressor running at full load with an aftercooler. For cooler water or a partially loaded compressor, slightly less water is required. However, for hotter water the flow requirements are significantly greater.

Table 2-Ventilation Requirements indicates the ventilation requirements necessary to keep the compressor running at a normal operating tempera-

ture. The fan air requirement is the volume of air which must flow through the compressor for proper ventilation. The specified heat rejection requirement is the amount of heat that is radiated by the compressor. This heat must be removed to assure a normal operating temperature. With air-cooled compressors it is possible to use this heat for space heating, providing no additional pressure drop is created across the fan. Consult a Sullair office for assistance in utilizing this heat.

**DO NOT** install a water-cooled or an air-cooled/aftercooled compressor where it will be exposed to temperatures less than 32\_F(0\_C).

**4.3 SERVICE AIR PIPING**

Service air piping should be installed as shown in Figure 4-1. A shut-off valve should be installed to isolate the compressor from the service line if required. Also notice that the service line should be equipped with water legs and condensate drains throughout the system.



**“The Plastic Pipe Institute recommends against the use of thermoplastic pipe to transport compressed air or other compressed gases in exposed above ground locations, e.g. in exposed plant piping.” (I)**

**Sullube should not be used with PVC piping systems. It may affect the bond at cemented joints. Certain other plastic materials may also be affected.**

**(I) Plastic Pipe Institute, Recommendation B, Adopted January 19, 1972.**

**TABLE 1-WATER SUPPLY REQUIREMENTS (WATER-COOLED)**

WATER TEMP. 0 F / C	WATER FLOW (I) GPM/ LPM		
	25HP/ 18KW	30HP/ 22KW	40HP/ 30KW
70/ 21	3.75/ 14.2	4.50 /17.0	5.75/ 21.8
80/ 26.6	5.00/ 18.9	6.00/ 22.7	7.50 /28.4

**(I) Water pressure should be between 25 and 75 psig/ 1.7 and 5.2 bar.**

**TABLE 2-VENTILATION REQUIREMENTS (I)**

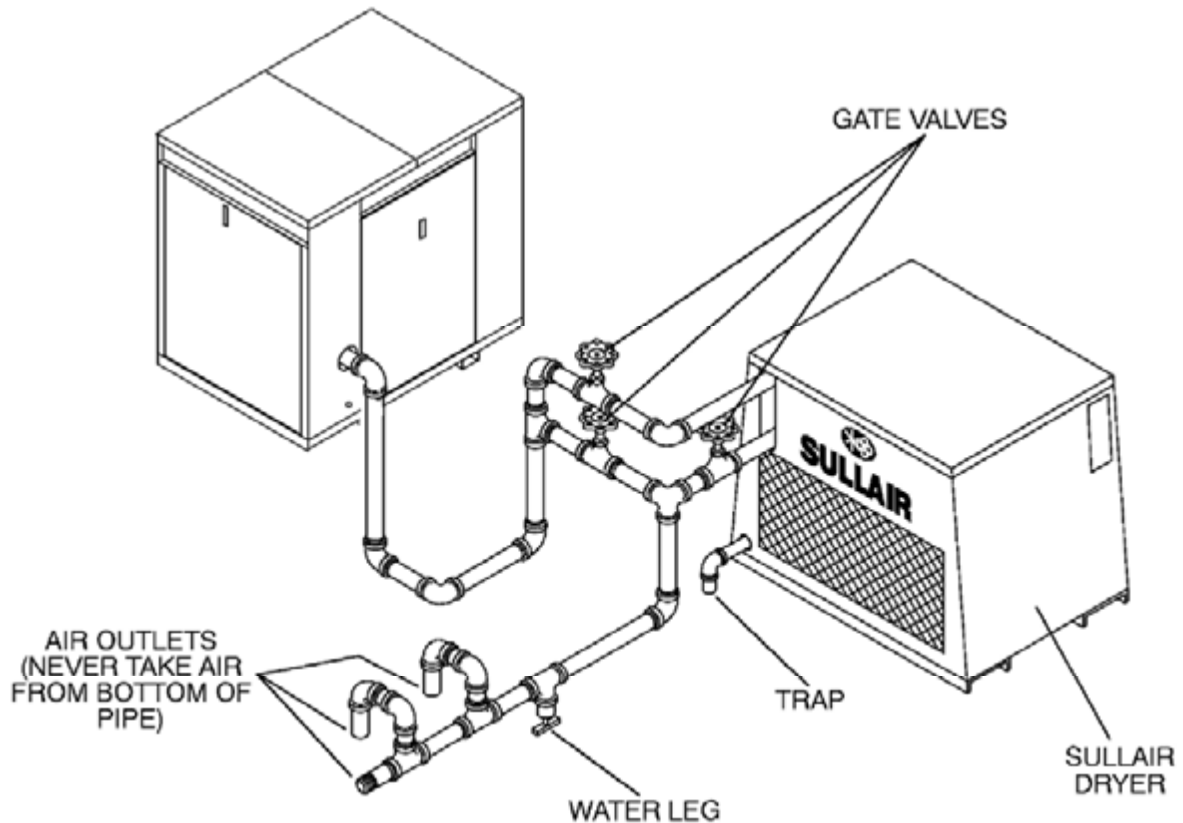
Cooling Type	Air-cooled with Aftercooler			Water-cooled		
Motor HP/KW	25/18	30/22	40/30	25/18	30/22	30/40
Fan Air CFM M <sup>3</sup> /Hr (II)	2500/4250	2500/4250	3500/5950	720/1220	720/1220	720/1220
Ventilating Air/ Heat Rejection BTU/Hour KCal/Hour	76980/ 19500	88800/ 22500	118320/ 29900	8500/ 2150	10000/ 2550	13000 3300
Cooling Water/ Heat Rejection BTU/Hour Kcal/Hour				76980/ 19500	88800/ 22500	118320/ 29900

**(I) Values based on: 100% RH, 85\_F/ 29\_C Ambient**

**(II) Applies to compressor with canopy only (vent fan).**

## Section 4 INSTALLATION

Figure 4-1 Service Air Piping with Aftercooler and Optional Air Dryer (Typical)



### 4.4 COUPLING ALIGNMENT CHECK

No coupling alignment is required.

### 4.5 FLUID LEVEL CHECK

The air compressor is also supplied with the proper amount of fluid. However, it is necessary to check the fluid level at installation. The level is checked by looking at the sight glass located near the sump. If the sump is properly filled, fluid should be visible in the sight glass. The maximum fluid level is the level of the filler port.

### 4.6 ELECTRICAL PREPARATION- STANDARD ELECTRO-MECHANICAL

Interior electrical wiring is performed at the factory. Required customer wiring is minimal, but should be done by a qualified electrician in compliance with OSHA, National Electrical Code, and/or any other applicable State, Federal and local electrical codes concerning isolation switches, fused disconnects, etc. Sullair provides a wiring diagram for use by the installer.

#### NOTE

Customer must provide electrical supply power disconnect within sight of machine.

A few electrical checks should be made to help assure that the first start-up will be trouble-free.

#### ⚠ WARNING

Lethal shock hazard inside. Disconnect all power at source before opening or servicing.

1. Check incoming voltage. Be sure that compressor is wired for the correct incoming voltage.
2. Check starter for correct size, proper overload relay, and heaters.
3. Check all electrical connections for tightness.
4. "DRY RUN" the electrical controls by disconnecting the three (3) motor leads from the starter. Energize the control circuits by pressing the "I" pad, and check all protective devices to be sure that they will de-energize the starter coil when tripped.

5. Reconnect the motor leads and jog the motor for a direction of rotation check as explained in Section 4.8.

**NOTE**

Wiring diagram for standard compressors is supplied on the inside cover of the Control Center. Optional compressor wiring diagrams will vary.

**4.7 ELECTRICAL PREPARATION - SUPERVISOR II**

Interior electrical wiring is performed at the factory. Required customer wiring is minimal, but should be done by a qualified electrician in compliance with OSHA, National Electric Code and/or any applicable local electrical code concerning isolation switches, fused disconnects, etc. Sullair provides a wiring diagram for use by the installer.

An electrical check should be made to help assure that the first start-up will be trouble-free.

**▲ DANGER**

Lethal shock hazard inside. Disconnect all power at source, before opening or servicing.

1. Check incoming voltage. Be sure that the incoming voltage is the same voltage that the compressor was wired for.
2. Check starter and overload heater sizes.
3. Check all electrical connections for tightness.
4. "DRY RUN" the electrical controls by disconnecting the three (3) motor leads from the starter. Energize the control circuits by pushing the "I" (START) pad and check all protective devices to

be sure that they will de-energize the starter coil when tripped.

5. Reconnect the three (3) motor leads and jog the motor for a direction of rotation check, as explained in Section 4.9.

**4.8 MOTOR ROTATION DIRECTION CHECK**

**NOTE**

Motor rotation check must be made at compressor start-up. Remove compressor panel as needed to view motor rotation.

After the electrical wiring has been done, it is necessary to check the direction of the motor rotation.

Pull out the **EMERGENCY STOP** button and press once, quickly and in succession, the "I" (START) and "O" (STOP) pads. This action will bump start the motor for a very short time. When looking at the motor from the end opposite the compressor unit, the shaft should be turning clockwise. If the reversed rotation is noted, disconnect the power to the starter and exchange any two of the three power input leads, then re-check rotation. A "Direction of Rotation" decal is located on the motor to show proper motor/compressor rotation.

An alternative to this procedure is to set the Supervisor to display P1. Pull out the **EMERGENCY STOP** button and press once, quickly and in succession, the "I" (START) and "O" (STOP) pads. This action will bump start the motor for a very short time. If motor rotation is correct there will be immediate pressure shown. If no pressure is present, reverse rotation is occurring. Disconnect the power to the starter and exchange any two of the three power input leads. Recheck rotation as outlined above.

# NOTES


# OPERATION- ELECTRO-MECHANICAL

## 5.1 GENERAL

While Sullair has built into this compressor a comprehensive array of controls and indicators to assure you that it is operating properly, you will want to recognize and interpret the reading which will call for

service or indicate the beginning of a malfunction. Before starting your Sullair compressor, read this section thoroughly and familiarize yourself with the controls and indicators – their purpose, location and use.

## 5.2 PURPOSE OF CONTROLS-STANDARD ELECTRO-MECHANICAL

CONTROL OR INDICATOR	PURPOSE
EMERGENCY STOP SWITCH	Pushing in this switch, found adjacent to the controller, cuts all AC outputs from the latter and de-energizes the starter. A fault message (E STOP) is displayed by the Supervisor until the button is pulled out and the "O" pad is depressed.
START "I" PAD	Depress to turn the compressor ON.
STOP "O" PAD	Depress to turn the compressor OFF and reset the common fault circuit.
AUTO "ⓐ" PAD	To select between continuous (HAND) operation and automatic stop/start (AUTO) operation. Shuts off compressor automatically after the compressor runs unloaded for a specified time (ranging from 3–60 minutes [T1]). Restarts compressor when the pressure switch trips to the reload setting. Dual control is enabled by pressing the "AUTO" pad.
HOURMETER	Records cumulative hours of compressor operation; useful for planning and logging service schedules.
LINE PRESSURE GAUGE	Continually monitors service line air pressure. It is located on dry side of receiver downstream from check valve.
SUMP PRESSURE GAUGE	Continually monitors receiver/sump pressure at various load and/or unloaded conditions.
DISCHARGE TEMPERATURE GAUGE	Monitors temperature of the air leaving the compressor unit. For both air and water-cooled compressors, the normal reading should be approximately 180_F to 205_F (82_C to 96_C).
AIR FILTER RESTRICTION GAUGE	Indicates when the air filter element change is required. The gauge shows the red zone when drop through the filter is excessive. The compressor must be running full load for an accurate indication.
FLUID FILTER MAINTENANCE GAUGE	Indicates when a fluid filter element change is required. It shows red when the pressure drop through the filter is excessive.
SEPARATOR MAINTENANCE GAUGE	Indicates when separator element change is required. Shows red when the pressure drop through the filter is excessive. The compressor must be running full load for an accurate indication.
POWER ON (  ) LED	Indicates when the starter is receiving power.
ON LED	Indicates when compressor is in operation.
AUTO LED	Indicates when compressor is in auto mode.

## Section 5

# OPERATION- ELECTRO-MECHANICAL

### 5.2 PURPOSE OF CONTROLS-STANDARD ELECTRO-MECHANICAL (CONTINUED)

CONTROL OR INDICATOR	PURPOSE
FLUID LEVEL SIGHT GLASS	Monitors fluid level in the sump. The fluid must be visible in the glass. Check the level when the compressor is shut down. Maximum fill level is the level of the fill port, minimizing the risk of overfilling.
SEPARATOR RETURN LINE SIGHT GLASS	Used to indicate fluid flow in the return line. When the compressor is running at full load, fluid flow should be visible in this sight glass. There may be little or no flow when the compressor is running unloaded, but a sluggish flow at full load indicates a need to clean the return line strainer.
THERMAL VALVE	Regulates flow of fluid to and around the cooler. It is designed to maintain a minimum operating temperature of 180_F (82_C); use for fast warm-up on start-up.
MINIMUM PRESSURE/CHECK VALVE	Maintains minimum of 55 psig (3.8 bar) in the compressor sump. Valve piston restricts receiver air discharge from receiver/sump when pressure falls to 55 psig (3.8 bar). Also prevents backflow into the sump during unload conditions and after shutdown.
COMPRESSOR DISCHARGE TEMPERATURE SWITCH	Designed to shut the compressor down when the discharge temperature reaches 235_F (113_C).
WATER PRESSURE SWITCH (water-cooled compressors only)	It prevents operation when water pressure of compressor is inadequate.
PRESSURE RELIEF VALVE	Opens sump pressure to the atmosphere should pressure inside the sump become too high. Operation of this valve indicates that the high pressure switch is either faulty or out of adjustment.
MODULATING INLET VALVE	Regulates the amount of air allowed to enter the air compressor. This regulation is determined by the amount of air being used at the service line. Also acts as a check valve to prevent reverse compressor rotation at shut down.
PRESSURE REGULATOR	Allows a pressure signal to reach the air inlet valve to control air delivery according to demand.
SOLENOID VALVE	Bypasses the pressure regulator valve causing the inlet valve to close when the compressor reaches maximum operating pressure. Also activates blow-down valve.
PRESSURE SWITCH	Senses service line pressure. When line pressure reaches maximum setting the pressure switch signals the pilot valves to unload the compressor.
BLOWDOWN VALVE	Vents sump pressure to the atmosphere during unload conditions and shutdown.
WATER REGULATING VALVE (water-cooled only)	Regulates the amount of cooling water used to keep the compressor running at a normal operating temperature.
T1 (AUTOMATIC STOP TIMER)	Adjustable from three (3) to 60 minutes. Located on rear of the controller.

# OPERATION- ELECTRO-MECHANICAL

## 5.2 PURPOSE OF CONTROLS-STANDARD ELECTRO-MECHANICAL (CONTINUED)

CONTROL OR INDICATOR	PURPOSE
T2 (BYPASS TIMER)	Adjustable from zero (0) to 16 seconds. Used to bypass the water pressure switch on startup. Set to zero (0) for no function. Located on rear of controller.
T3 (STAR-DELTA TIMER)	Adjustable from zero (0) to 16 seconds. Transition timer for Wye-delta start. Located on rear of controller.
SW1 (POWER FAILURE RESTART ON/OFF CONTROL)	With switch set to ON, machine will start after power recovery in the run mode selected prior to power failure as long as start permissives allow. Located on rear of controller.

### 5.3 INITIAL START-UP PROCEDURE- STANDARD ELECTRO-MECHANICAL

The following procedure should be used to make the initial start-up of the compressor:

1. Read the preceding pages of this manual thoroughly.
2. Be sure that all preparations and checks described in the Installation Section have been made.
3. Crack open the shut off valve to the service line.
4. Start the compressor by pressing the START "I" pad.
5. Check for possible leaks in piping.
6. Slowly close the shut-off valve and check that the setting on the pressure switch is set correctly. If set correctly, the compressor will unload at the desired unload pressure. If adjustments are necessary, see Control System Adjustment in the Maintenance Section 7.7 of this manual.

7. Observe the operating temperature. If the operating temperature exceeds 205\_F (96\_C), the cooling system or installation environment should be checked.
8. Observe return line sight glass and maintenance indicators.
9. Open shut-off valve to service line.
10. Reinspect the compressor for temperature and leaks the following day.

### 5.4 SUBSEQUENT START-UP PROCEDURE-STANDARD ELECTRO-MECHANICAL

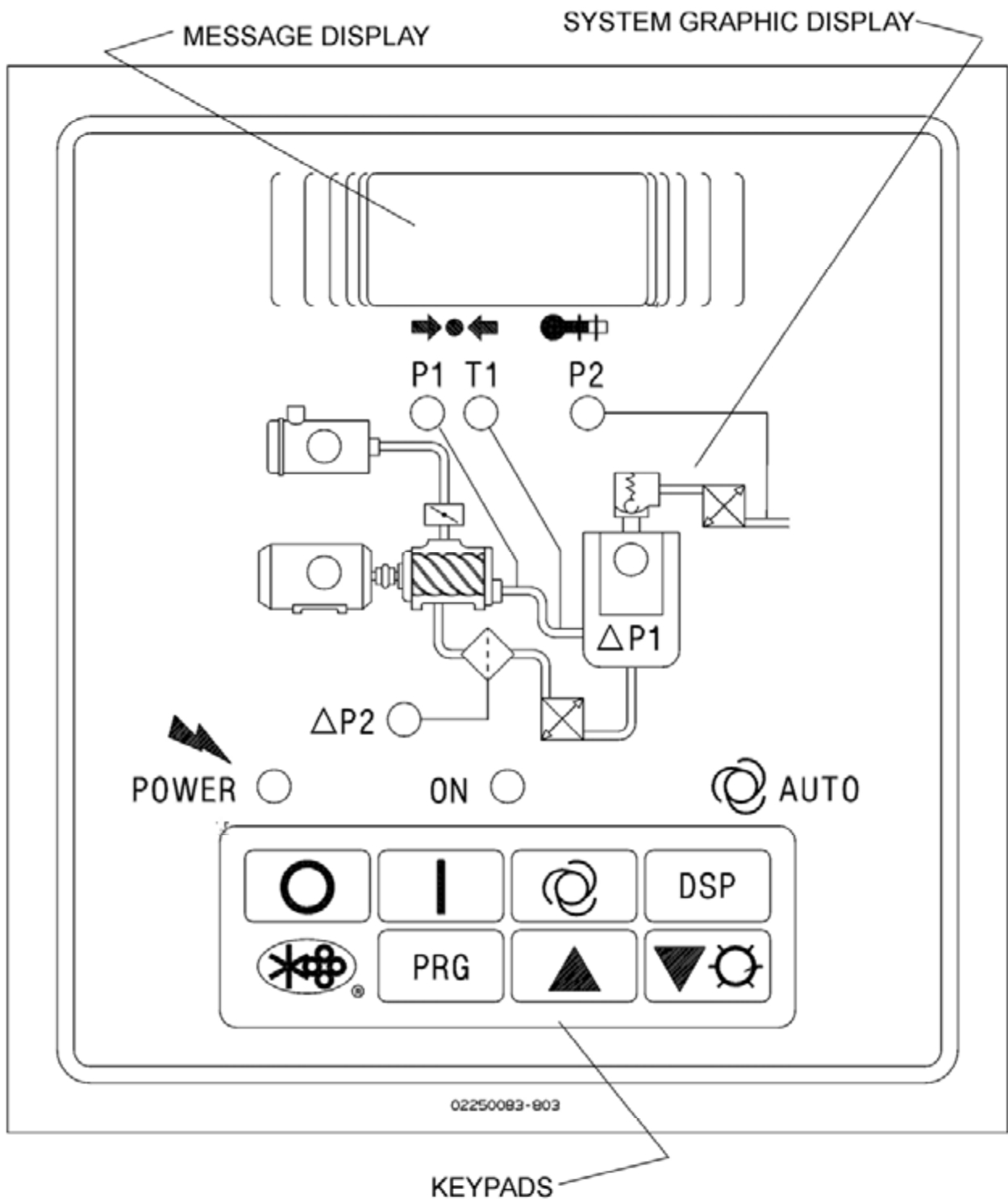
On subsequent start-ups, check that fluid level is visible in the fluid sight glass and simply press the START pad. When the compressor is running, observe the instrument panel and maintenance indicators.

### 5.5 SHUTDOWN PROCEDURE- STANDARD ELECTRO-MECHANICAL

To shut the compressor down, simply press the STOP "O" pad.

# OPERATION- SUPERVISOR II

Figure 6-1 Supervisor II Panel



**6.1 INTRODUCTION**

Refer to Figure 6-1 for information regarding your compressor with Supervisor II. The Supervisor II has a two line display to show temperature, pressure and status. It has a keypad for operating the compressor, programming the control points and selecting displays. There is a graphic illustration with lamps that light to show the item being displayed. The lamps flash if that component is in an alarm condition.

**6.2 KEYPAD**

The keypad is used to control the machine as well as display status and change setpoints. Refer to figure 6-1 for following key descriptions.

§ **Stop** - Used to put the machine into manual stop. It is also used to clear alarm conditions.



§ **Continuous** - Starts machine if no alarm conditions are present. Also used to clear alarm conditions while machine is running.



§ **Auto** - Starts machine and selects auto mode if no alarm conditions are present. Also used to clear alarm conditions while machine is running.



§ **Display** - Used to display pressures, temperatures and other status information (See section on STATUS DISPLAYS).



§ **Logo** - Used for various functions described in later sections.



§ **Program** - Used to enter the parameter change mode where control parameters may be displayed and changed (See PARAMETER SETUP).



§ **Up arrow** - Used in status displays to change displays and in parameter setup mode to increment a value.



§ **Down arrow, lamp test** - Used in status displays to change displays and in parameter setup mode to increment a value. When in the default display the key will light all the lamps for three seconds.



**6.3 STATUS DISPLAYS**

By default the line pressure (P2) and discharge temperature (T1) are shown on the bottom line of the display, and machine status on the top line. The following are the various machine status messages that indicate the state of the compressor with LCD graphics listed below:

§ **STOP** - Compressor is off.

§ **STANDBY** - Compressor is off but armed to start. This state may be entered because of a power up, or the unload timer had expired and stopped the machine. NOTE : The machine may start at any time.

§ **STARTING** - Machine is trying to start.

§ **OFF LOAD** - Machine is running and off loaded.

§ **ON LOAD** - Machine is running and loaded.

§ **FULL LD** - Machine is running and fully loaded. This state is only displayed if the machine has a full load valve and under sequence control.

§ **RMT STOP** - Compressor is off but armed to start. The machine will start when the remote start contact is closed. NOTE : the machine may start at any time.

§ **SEQ STOP** - Compressor is off but armed to start. The machine will start when the sequencing conditions meet the criteria to start. NOTE : the machine may start at any time.

This default display appears as follows:

If there are alarms active they will alternately be shown with the default display. The machine status will be displayed for two seconds, then the alarms

## Section 6

# OPERATION- SUPERVISOR II

STOP  
110 180

for two seconds each. For example:

T1 HI  
110 180

To view other status press the DSP key. All temperatures and pressures may be displayed as well as other status information. To scroll through the displays press the up arrow or down arrow keys. Up arrow moves to the next display, down arrow the previous display. To return to the default display press the display key.

S Separator differential pressure and the maximum limit. If the limit is exceeded, a separator maintenance warning will be displayed.

nP1 4  
MAX 10

S Sump pressure and line pressure.

P1 113  
P2 108

S Pressure after (P3) oil filter.

P3 108

S Oil differential pressure and the minimum limit. If the pressure goes below the limit a P3 LOW shutdown will occur. Oil differential (dP3) is defined as P3-P1/2

dP3 40  
MIN 1

S Unit discharge temperature and the maximum limit. If the temperature exceeds the limit a T1 HI shutdown will occur.

T1 210  
MAX 235

S Total hours that the compressor has been running.

HRS RUN  
001234.0

S Total hours that the compressor has been loaded.

HRS LOAD  
000987.0

S Last fault log. This shows the fault on the first line and the run hours when the fault occurred.

T1 HI  
@1 234

S Next to last fault log. This shows the fault on the first line and the run hours when the fault occurred.

T1 HI  
@2 204

### 6.4 LAMP INDICATORS

Embedded into the front panel schematic of the compressor are several lamps. Pressing the lamp test key will light all the lamps for three seconds. Each LED lamp has the following purpose.

**P1** - If lit steady, signifies that P1 is being displayed; if flashing denotes the presence of an alarm.

**P2** - If lit steady, signifies that P2 is being displayed; if flashing denotes the presence of an alarm.

**ΔP1** - If lit steady, signifies that ΔP1 is being displayed; if flashing denotes replacement of separator is needed.

**ΔP2** - If lit, indicates replacement of fluid filter is needed.

**T1** - If lit steady, signifies that T1 is being displayed; if flashing denotes the presence of an alarm.

**INLET FILTER** - Same as ΔP2.

**MOTOR** - If flashing, indicates the motor overload contact has opened.

**POWER ON** - Lit if 120VAC power is applied to the Supervisor II.

**ON** - If lit steady, the compressor is running. If flashing, indicates that the compressor is armed but stopped because of restart timer not expired, remote stop or sequence stop. The compressor may start at any time.

**AUTO** - If lit steady, the compressor is running and in auto mode. If flashing, indicates that the compressor is armed but stopped because of restart timer not expired, remote stop or sequence stop. The compressor may start at any time.

**6.5 OPERATION INTRODUCTION**

While Sullair has built into this compressor a comprehensive array of controls and indicators to assure you that it is operating properly, you will want to recognize and interpret the readings which will call for service or indicate the beginning of a malfunction. Before starting your Sullair compressor, read this section thoroughly and familiarize yourself with the controls and indicators - their purpose, location and use.

**6.6 SUPERVISOR II PARAMETER SETUP**

Pressing the program key enters parameter display and edit mode. To move to the next parameter press the program key. To increment a parameter press the up arrow key or logo key. The logo key will increment by 10. To decrement the value press the down arrow key.

The parameters are displayed in the following order:

**S Unload pressure** - The pressure where the machine is unloaded. For example if this parameter is set to 110 psi (7.6 bar) the machine will unload when the line pressure is above 110 psi (7.6 bar).

**UNLOAD  
100 PSI**

**S Load differential** - The pressure differential below the unload pressure where the machine is loaded. For example, if the unload pressure is set to 110 psi (7.6 bar) and the load differential is set to 10 psi (0.7 bar), the machine will load when the line pressure goes below 100 psi (6.9 bar).

**LOAD  
10 PSI**

**S P1 Max** - Maximum sump pressure. An alarm and shut down will occur when the sump pressure rises above this pressure.

**P1 MAX  
135 PSI**

**S Wye to delta transition timer** - For full voltage starters this parameter is set to 0.

**WYE DELT  
10 SEC**

**S Restart time** - Time to wait after power up before starting machine. This parameter is used to keep several machines from starting at the same time after power up, or to delay start until other equipment is started.

If disabled the machine will not automatically start after power up.

**RST TIME  
10 SEC**

**S Unload Stop Timer** - If the machine is running in AUTO mode, this parameter specifies the amount of time that the machine will run unloaded before shutting off. If the time is set less than 15 minutes (for example five minutes), there may be times when the machine will run unloaded for more than five minutes. This is because there is another timer that keeps the machine from being started more than four times an hour.

**UNLTD TIM  
15 MIN**

**S Language select** - English, German, Spanish, Italian and French may be selected for display language.

**LANGUAGE  
ENGLISH**

**S Units** - English or metric units may be selected.

**UNITS  
ENGLISH**

**S Communications ID #** - This is the network address of a machine. If there is more than one machine connected to the network, each machine must have a unique number.

**COM ID #  
1**

**S Communications baud rate** - This should always be selected to 9600 baud for all sequencing modes. It may be lower for slave or monitoring modes.

**BAUDRATE  
9600**

**S Sequence method** - This parameter sets the method used for optional sequencing. The choices are DISABLED, REMOTE, SLAVE, HOURS, COM ID#. See the Sequencing & Protocol Manual (See Recommended Spare Parts List) for details about

# OPERATION- SUPERVISOR II

these modes.

SEQUENCE  
HOURS

S **Drain interval** - The time between actuation of the drain valve.

DRN INTV  
10 MIN

S **Drain time** - The amount of time that the drain valve is actuated.

DRN TIM  
1 SEC

S **Last Communication Number** - Used only for sequencing, see Sequencing & Protocol Manual for details.

LAST COM  
3

S **Lowest Allowable Pressure** - Used only for sequencing, see Sequencing & Protocol Manual for details.

LOWEST  
90 PSI

S **Recovery Time** - Used only for sequencing, see Sequencing & Protocol Manual for details.

RECOVER  
10 SEC

S **Rotate Time** - Used only for sequencing - units in HOURS, see Sequencing & Protocol Manual for details.

ROTATE  
50 HOURS

S **Machine Capacity** - Used only for sequencing - units in CFM (M<sup>3</sup>/min), see Sequencing & Protocol Manual for details.

CAPACITY  
100

S **Sequence Hours** - Used only for sequencing, see Sequencing & Protocol

Manual for details.

SEQ HRS  
1000

## 6.7 OPERATING THE COMPRESSOR

Before operating the compressor the operating parameters must be setup. See the previous section on operating parameter setup.

### MANUAL OPERATION MODE

In this mode the compressor will run indefinitely, as long as temperatures and pressure remain within the valid operating ranges, and the motor overload or emergency stop contacts are not tripped. Pressing the "I" will turn on the compressor and put it in manual mode. If the compressor is already running, but in automatic mode, pressing "I" will switch operation to manual. Pressing "I" while already running in manual mode will cause the Supervisor to turn off the common fault relay, if engaged, and clear any maintenance indicators.

To stop the compressor, press "O". If the compressor is already off when "O" is pressed, the common fault relay will be turned off, if engaged, and it will try to clear the alarm and maintenance indicators. Regardless of what the compressor is doing, pressing "O" puts the Supervisor in manual stop mode.

### AUTOMATIC OPERATION MODE

In this mode the compressor will start if line pressure (P2) is less than the **LOAD** parameter. It will stop if the compressor runs unloaded for the number of minutes indicated by the **UNLD TIM** parameter. To put the compressor in automatic mode press "A". If P2 is already less than **LOAD** the compressor will start immediately, otherwise the system status will indicate **STANDBY** and the LED marked **AUTO** will flash.

If the compressor is already running, but in continuous mode, pressing "A" will switch operation to automatic. Pressing "A" while already running in automatic mode will cause the Supervisor to turn off the common fault relay, if engaged, and clear any maintenance indicators.

In automatic mode the compressor can be stopped manually by pressing "O". Stopping the compressor using "O" will put the Supervisor in manual stop mode.

Regardless of whether in "automatic" or "manual" mode, control of the load solenoid will be based on the parameters **UNLD** and **LOAD**. This operation is as follows:

**P2 > UNLD --> load solenoid turned off**  
**P2 < LOAD --> load solenoid turned on**

### POWER FAILURE RESTART

If the restart timer (RST TIME parameter) is dis-

## Section 6

# OPERATION- SUPERVISOR II

abled the compressor will not try to start after a power up. If this time is set to a value, the machine will go into standby after power up. When the line pressure drops below the load setpoint, the restart timer will start timing. When the timer expires the machine will start.

### SEQUENCING MODES

The following is a brief description of sequencing modes. For details see the Supervisor II Sequencing & Protocol Manual (See Recommended Spare Parts List).

**\$ DISABLED** - Responds to status and parameter change messages via the RS485 network but will not respond to start, stop, load or unload messages.

**\$ REMOTE** - Responds to status and pa-

parameter change messages but will not respond to start, stop, load or unload messages. The remote inputs and outputs are enabled (start/stop, load/unload, master/local).

**\$ SLAVE** - Will respond to all messages, but will not start or load unless commanded to do so by a message. This mode is used to control the machine from a master computer.

**\$ HOURS** - Sends status message about once a second; starts, loads and unloads machines based on sequencing hours.

**\$ COM ID #** - Sends status message about once a second; starts, loads and unloads machines based on machine COM ID#.

## 6.8 PURPOSE OF CONTROLS - SUPERVISOR II

CONTROL OR INDICATOR	PURPOSE
EMERGENCY STOP SWITCH	Pushing in this switch, found adjacent to the Supervisor, cuts all AC outputs from the latter and de-energizes the starter. A fault message (E STOP) is displayed by the Supervisor until the button is pulled out and the "O" pad is depressed.
DISCHARGE TEMPERATURE PROBE-T1	Shuts the compressor down when the compressor discharge temperature exceeds 240_F (116_C). Continually monitors air/fluid mixture discharged from the compressor unit.
AIR END DISCHARGE PRESSURE-P1	Shuts the compressor down when the compressor discharge pressure exceeds P1 MAX. Continually monitors the discharge pressure of the compressor unit. Indicates pressure in compressor sump upon start-up to verify rotor motor rotation.
PACKAGE OUTLET PRESSURE-P2 (Service Line Pressure)	Continually monitors service line pressure. When line pressure reaches the UNLOAD setting, the Supervisor control signals the solenoid valve to unload the compressor.
FLUID PRESSURE-P3	Continually monitors injection fluid pressure and shuts down the compressor in the event of low fluid pressure.
FLUID FILTER DIFFERENTIAL SWITCH	Continually monitors fluid filter differential and generates an alarm when the fluid filter needs replacement.
INLET FILTER MAINTENANCE SWITCH	Monitors condition of compressor inlet air filter and indicates when replacement is required.
FLUID LEVEL SIGHT GLASS	Indicates fluid level in the sump. Proper level is not to fall below the center of the sight glass. Check level when compressor is shut down. <b>DO NOT OVERFILL.</b>
COOLER BYPASS VALVE	Regulates flow of fluid to and around the cooler. Designed to maintain a minimum operating temperature of 180_F (82_C); used for fast warm-up on start-up.

## Section 6

# OPERATION- SUPERVISOR II

### 6.8 PURPOSE OF CONTROLS - SUPERVISOR II (CONTINUED)

CONTROL OR INDICATOR	PURPOSE
MINIMUM PRESSURE/CHECK VALVE	Maintains minimum of 50 psig (3.4 bar) in the compressor sump. Valve piston restricts receiver air discharge from receiver/sump when pressure falls to 50 psig (3.4 bar). Also incorporated in this valve is a terminal check valve which prevents line pressure backflow into the sump during unload conditions and after shutdown.
PRESSURE RELIEF VALVE	Protects compressor by venting compressed air in excess of 200 psig (13.8 bar) to atmosphere.
MODULATING INLET VALVE	Regulates the amount of air allowed to enter the air compressor. This regulation is determined by the amount of air being used at the service line. Also acts as a check valve to prevent reverse compressor rotation at shut down.
SOLENOID VALVE	Bypasses the pressure regulator valve causing the inlet valve to close when the compressor reaches maximum operating pressure. Also activates blowdown valve.
WATER REGULATING VALVE (water-cooled only)	Regulates the amount of cooling water used in the cooler to keep the compressor running at a normal operating temperature of 170_F (77_C).

### 6.9 SUPERVISOR II OUTPUT RELAYS

RELAY	OPERATION
RUN RELAY (K1) *-DELTA (K2)	Contact closure energizes the compressor starter. A timed contact used to provide wye-delta transition time.
UNLOAD/LOAD (K3)	Controls ON LOAD/OFF LOAD operation of the load control solenoid valve.
COMMON FAULT (K4)	May be used to provide remote indication of any pre-alarm, maintenance or fault shutdown condition.
DRAIN VALVE (K5)	Controls optional solenoid valve to provide automatic condensate removal.
FULL LOAD/MODULATE (K6)	Used with optional sequencing feature.

**NOTE:** All output relays will handle eight (8) amps at 120/240 VAC.

### 6.10 INITIAL START-UP PROCEDURE- SUPERVISOR II

The following procedure should be used to make the initial start-up of the compressor.

1. Read the preceding pages of this manual thoroughly.
2. Jog motor to check for correct rotation of motor (refer to Section 4.8).
3. Be sure that all preparations and checks described in the Installation Section have been made.
4. Open the shut-off valve to the service line.
5. Check for possible leaks in piping.
6. Slowly close the shut-off valve to assure proper nameplate pressure unload setting is correct. The compressor will unload at nameplate pres-

## OPERATION- SUPERVISOR II

sure. If adjustments are necessary, see Control System Adjustments.

7. Observe the operating temperature. If the operating temperature exceeds 200\_F (93\_C), the cooling system and installation environment should be checked.
8. Open shut-off valve to the service line.
9. Reinspect the compressor for temperature and leaks the following day.

### 6.11 SUBSEQUENT START-UP PROCEDURE- SUPERVISOR II

On subsequent start-ups, check that the proper level is visible in the fluid level sight glass and simply press "1" for manual or "Ⓞ" for automatic operation. When the compressor is running, observe the various parameter displays.

### 6.12 SHUTDOWN PROCEDURE- SUPERVISOR II

To shut the compressor down, push "O" pad.

# NOTES

**7.1 GENERAL**

As you proceed in reading this section, it will be easy to see that the Maintenance Program for the air compressor is quite minimal. The use of the service indicators provided for the bearing filter, air filter and fluid separator, will alert you when service maintenance is required. When the maintenance gauge shows red, maintenance for that specific item is required. See instructions for each item in Section 7.8, Parts Replacement and Adjustment procedures.

**7.2 DAILY OPERATION**

Prior to starting the compressor, it is necessary to check the fluid level in the sump. Should the level be low, simply add the necessary amount. If the addition of fluid becomes too frequent, a simple problem has developed which is causing this excessive loss. See the Troubleshooting Section under Excessive Fluid Consumption for a probable cause and remedy.

After a routine start has been made, observe the instrument panel gauges and be sure they monitor the correct readings for their particular phase of operation. After the compressor has warmed up, it is recommended that a general check on the overall compressor and instrument panel be made to assure that the compressor is running properly.

**▲ WARNING**

**DO NOT** remove caps, plugs, and/or other components when compressor is running or pressurized.

Stop compressor and relieve all internal pressure before doing so.

**7.3 MAINTENANCE AFTER INITIAL 50 HOURS OF OPERATION**

After the initial 50 hours of operation, a few maintenance requirements are needed to clean the system of any foreign materials. Perform the following maintenance operations to prevent unnecessary problems.

1. Clean the return line strainer.
2. Clean the return line orifice.

**7.4 MAINTENANCE EVERY 1000 HOURS**

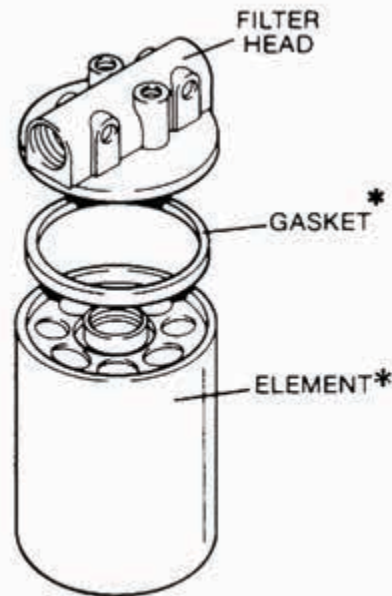
After 1000 hours of operation, it will be necessary to perform the following:

1. Clean the return line strainer.
2. Replace the fluid filter element and gasket.

**7.5 FLUID MAINTENANCE**

Drain the sump and change the compressor fluid using instructions shown in sections 3.2, 3.3, and 3.4.

*Figure 7-1 Fluid Filter (P/N 02250096-783)*



\* Repair Kit P/N 250025-525

**7.6 FILTER MAINTENANCE**

Replace your fluid filter element and the gasket under any of the following conditions, whichever occurs first:

1. As indicated by the maintenance gauge.
2. Every 1000 hours.
3. Every 6 months.

**7.7 SEPARATOR MAINTENANCE**

Replace the separator elements when your separator maintenance gauges show red or after one (1) year, whichever comes first. The separator elements must be replaced. **DO NOT** clean the separator elements.

**7.8 PARTS REPLACEMENT AND ADJUSTMENT PROCEDURES**

**FLUID FILTER ELEMENT REPLACEMENT**

Refer to Figure 7-1.

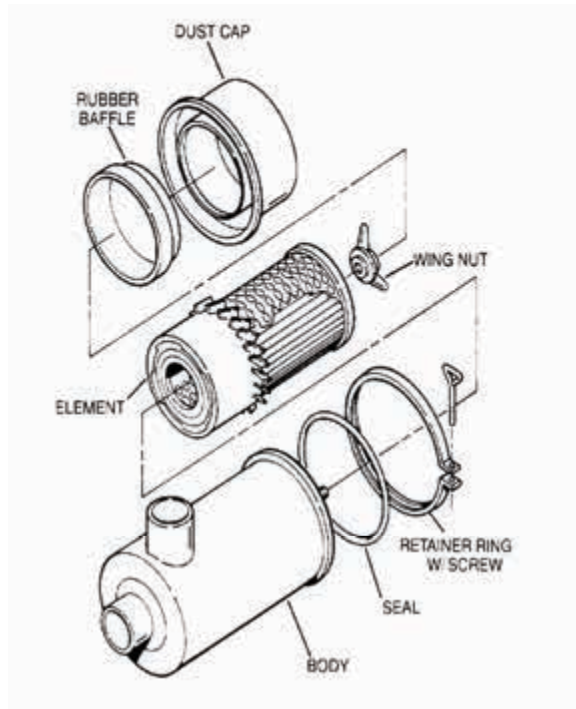
1. Using a strap wrench, remove the old element and gasket.
2. Clean gasket seating surface.
3. Apply a light film of fluid to the new gasket.
4. Hand tighten new element until new gasket is seated in the gasket groove. Avoid any nicks, cuts or pinches to the gasket.
5. Continue tightening element by hand an additional 1/2 to 3/4 turn.
6. Restart compressor and check for leaks.

**▲ CAUTION**

To minimize the possibility of filter element rupture, it is important that **ONLY** replacement elements identified with the Sullair name, logo and

## Section 7 MAINTENANCE

*Figure 7-2 Air Filter Replacement  
(P/N 02250107-327)- 25-30HP/ 18-22KW  
(P/N 040595)- 40HP/ 30KW*



\* Replacement Element P/N 043334 (25-30HP/18-22KW)  
Replacement Element P/N 040596 (40HP/30KW)

appropriate part number be used and that substituted elements not be used, due to the fact that such filters may have inadequate or questionable working pressure ratings.

### AIR FILTER MAINTENANCE

Refer to Figure 7-2. Air filter maintenance should be performed when the maintenance gauge shows red with the compressor running full load, or once a year, whichever comes first. If the filter needs to be replaced, order replacement elements. Below you will find procedures on how to replace the air filter elements.

### AIR FILTER ELEMENT REPLACEMENT

1. Clean exterior of air filter housing.
2. Release tension on cover retaining ring.
3. Remove the rubber baffle from the inside dust cup and empty the dirt from the dust cap.
4. Remove air filter element by loosening the wingnut securing the element.
5. Remove element and clean interior of housing using a damp cloth. **DO NOT** blow dirt out with compressed air.
6. At this time replace the element.
7. Reassemble in the reverse order of the disassembly.

8. Reset the air filter restriction indicator if equipped (electro-mechanical models only).

### ELEMENT INSPECTION

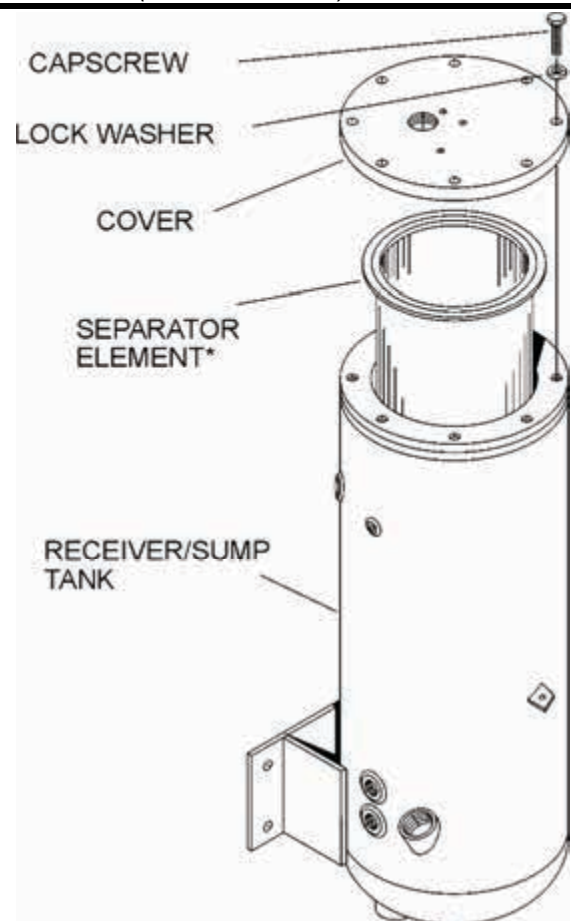
1. Place a bright light inside the element to inspect for damage or leak holes. Concentrated light will shine through the element and disclose any holes.
2. Inspect all gaskets and gasket contact surfaces of the housing. Should faulty gaskets be evident, correct the condition immediately.
3. If the clean element is to be stored for later use, it must be stored in a clean container.
4. After the element has been installed, inspect and tighten all air inlet connections prior to resuming operation.

### SEPARATOR ELEMENT REPLACEMENT

Refer to Figure 7-3. The separator elements must be changed when the maintenance gauge shows red with the compressor running full load, or once a year, whichever occurs first. Follow the procedure explained below for separator element replacement.

1. Relieve all pressure from the sump tank and all compressor lines.

*Figure 7-3 Separator Element Replacement  
(P/N 250034-113)*



\* Replacement Kit for Primary Element P/N 250034-114

## Section 7 MAINTENANCE

2. Disconnect all piping connected to the sump cover to allow removal (return lines, service lines, etc.).
3. Loosen and remove the eight (8) hex head cap-screws (1/2-13 x 1 1/2") from the cover plate.
4. Lift the cover plate from the sump.
5. Remove the separator element.
6. Inspect the receiver/sump tank for rust, dirt, etc.
7. Scrape the old gasket material from the cover and flange on the sump. Be careful not to let the scraps fall in the sump.
8. Reinsert the separator element into the sump taking care not to dent the element against the tank opening.
9. Clean the underside of the receiver/sump tank cover and remove any rust.
10. Replace the cover plate, washers and capscrews. Torque to 55 ft-lbs. (75 Nm).
11. Reconnect all piping making sure return line tubes extend to the bottom or 1/4" (6mm) above the bottom of the separator element. This will assure proper fluid return flow to the compressor.
12. Clean the return line strainers before restarting the compressor.

### CONTROL SYSTEM ADJUSTMENT

Refer to Figure 7-4. Prior to adjusting the Control System, it is necessary to determine the desired operating pressure range and also the maximum pressure at which your compressor is to operate. The pressure must not exceed the maximum operating

pressure which is stamped on the compressor serial number nameplate. The following explanation applies to a typical installation with a desired operating range of 115 to 125 psig (7.9 to 8.6 bar). This information will apply to a compressor with any other operating range excepting the stated pressures.

Remove the cover of the pressure switch. With the shut-off valve closed (or slightly cracked open) start the compressor. Observe the line pressure gauge and pressure switch contacts. When the line pressure reaches 125 psig (8.6 bar), the pressure switch contacts should open. If the pressure switch contacts do not open or they open prior to the desired pressure, the pressure switch setting will require adjustment (refer to Figure 7-4).

### FOR PRESSURE RANGE ADJUSTMENT:

1. Remove cover to pressure switch.
2. Turn the range adjusting screw to the high pressure setting. Turning the screw counterclockwise lowers both the high and low pressure equally.

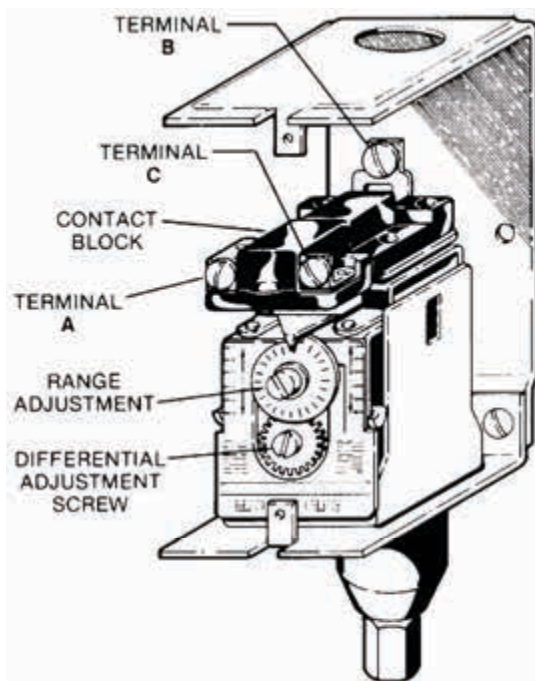
### FOR DIFFERENTIAL ADJUSTMENT:

Differential is the difference between the high and low pressure settings. 10 psig (0.7 bar) is typical.

1. Turn the differential adjusting screw to the lower (reset) setting. Turning the screw counterclockwise widens the differential by lowering the reset (lower) setting only.
2. When the pressure switch adjustment is complete, the pressure regulator should be adjusted for the pressure at which modulation of air delivery should begin. In this case that pressure will be 118 psig (8.2 bar). The regulator is adjusted by loosening the jam nut on the end of the cone shaped cover of the pressure regulator. When the jam nut is loose, turn the adjusting screw clockwise to increase or counterclockwise to decrease the setting.
3. To set the regulator, continue closing the service valve until the line pressure is 118 psig (8.2 bar). At this point regulator should pass a signal to the inlet valve to start closing it. If the line pressure keeps on rising or if the modulation does not begin, adjust the regulator valve as described above. After adjustment, line pressure should be approximately 118 psig (8.2 bar) and 1.00 in. Hg (2.54 cm Hg.) vacuum below the inlet.
4. Next, close the service valve; line pressure will start rising. When line pressure reaches 125 psig (8.6 bar), the inlet valve will be closed to its maximum position. The inlet vacuum at this point will be around 25 in. Hg (63.5 cm Hg.). The machine should unload at this point.
5. Open the service valve so the line pressure is 115 psig (7.9 bar). Machine is now set for operation. Recheck the unload pressure by closing of the service valve. Machine should unload via the pressure switch at 125 psig (8.6 bar).

After the control pressures have been adjusted, the "unloaded" sump pressure should be checked. It will

Figure 7-4 Pressure Switch  
P/N 040694- Standard  
P/N 407778- High Pressure



## Section 7

# MAINTENANCE

be necessary to shut the compressor down, remove the pressure switch cover, and disconnect one of the two lead wires that are connected to the micro-switch (contact block). After disconnecting the lead, tape the exposed wire with electrician's tape to make sure that it does not come in contact with any metallic surface.

### **▲ DANGER**

**DO NOT touch the electrical contacts, terminal or leads with any metallic object. Severe electrical shock may occur.**

With the lead taped, you may start the compressor again. Allow the sump pressure to stabilize.

The sump pressure should read 30 to 35 psig (2.1 to 2.8 bar).

Once this is checked, shut the compressor down once again and reconnect the taped lead and replace the pressure switch cover. At this time, start the compressor and cycle the Control System several times and re-check all pressure settings and adjustments.

### **▲ DANGER**

**DO NOT touch the pressure switch, electrical contacts, terminal board or leads with any part of the body or any un-insulated metallic object. Severe electrical shock may occur.**

### PRESSURE REGULATOR ADJUSTMENT

Start the compressor and adjust the service valve to maintain service air pressure at rated pressure (115 psig for example). Turn the adjusting screw on the regulator until air just begins to escape from the control air orifice. The regulator is now properly set.

### DRIVE COUPLING INSTALLATION AND MAINTENANCE

Refer to Figures 7-5 and 7-6. For coupling installation and maintenance the tools required will be a measuring scale, one set of standard Allen wrenches, and one set of standard socket wrenches.

For installation and maintenance of the drive coupling, follow the steps explained below.

### **▲ DANGER**

**Disconnect all power at source, before attempting maintenance or adjustments.**

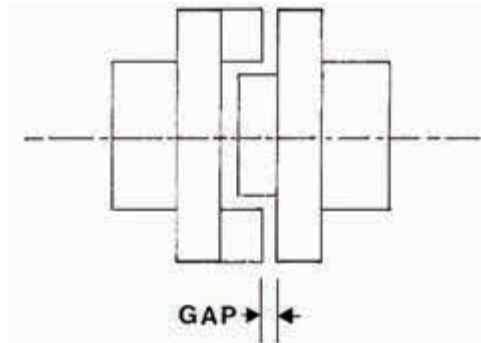
#### STEP 1 - COUPLING GUARDS

There are three 5/16" screws from each of the wire guards located on each side of the unit/motor adaptor for the 25/30 HP (18/22 KW) packages, or the two 3/8" bolt/nut/washer assemblies from the plate guard and adaptor located on the top side.

**TABLE 1 INSTALLATION DATA**  
**SERIES 10 (25-40HP/ 18-30KW)**

Horsepower	Coupling Element	Coupling Hub Gap	Tightening Torque (Wet)
25 & 30 HP/ 18 & 22 KW	045672	.09-.125 in 2.4-3.2 mm	55 ft.-lbs (75Nm)
60, 75, 100 (45, 55, 75 KW)	250004-638	.09-.125 in 2.4-3.2 mm	110 ft.-lbs (149Nm)

*Figure 7-5 Drive Coupling "Hub" Gap Check*



#### STEP 2 - MOUNTING HUBS/ELEMENT

The coupling halves have a unique bore for the motor and the air-end. The air-end half is to be located so that the hub is positioned against the shaft shoulder and secured in place by two set-screws. The motor half should remain free floating until the element is in its proper location. The motor half is then positioned within assembly maintaining an axial coupling gap as listed in Figure 7-5. There are two set-screws located on the motor coupling half also. Prior to starting of package, assure the set-screws are secure to eliminate potential movement of the hub.

### 7.9 TROUBLESHOOTING- STANDARD ELECTRO-MECHANICAL

The information contained in the Standard Electro-Mechanical Troubleshooting chart has been compiled from field report data and factory experience. It contains symptoms and usual causes for the described problems. However, **DO NOT** assume that these are the only problems that may occur. All available data concerning a problem should be systematically analyzed before undertaking any repairs or component replacement procedures.

A detailed visual inspection is worth performing for almost all problems and may avoid unnecessary additional damage to the compressor. Always remember to:

1. Check for loose wiring.
2. Check for damaged piping.

3. Check for parts damaged by heat or an electrical short circuit, usually apparent by discoloration or a burnt odor.

Should your problem persist after making the recommended check, consult your nearest Sullair representative.

**TROUBLESHOOTING- STANDARD ELECTRO-MECHANICAL**

SYMPTOM	PROBABLE CAUSE	REMEDY
COMPRESSOR WILL NOT START	Main Disconnect Switch Open	Close switch.
	Line Fuse Blown	Replace fuse.
	Control Transformer Fuse Blown	Replace fuse.
	Motor Starter Overloads Tripped	Reset. Should trouble persist, check whether motor starter contacts are functioning properly.
	Low Incoming Line Voltage	Check voltage. Should voltage check low, consult power company.
COMPRESSOR SHUTS DOWN WITH AIR DEMAND PRESENT	Loss of Control Voltage	Reset. If trouble persists, check that line pressure does not exceed maximum operating pressure of the compressor (specified on nameplate). Consult power company.
	Low Incoming Voltage	Consult power company.
COMPRESSOR SHUTS DOWN WITH AIR DEMAND PRESENT	Excessive Operating Pressure	Defect in line pressure switch; check pressure at which contact points open.
		Separator requires maintenance; check maintenance indicator under full load conditions.
		High pressure shutdown switch is defective; replace.
		Defective valve; regulator valve should cause inlet valve to close when the pressure switch contacts open. Repair if defective.
		Defective blowdown valve; blowdown valve should exhaust sump pressure to 10 to 15 psig (0.7 to 1.0 bar) when maximum operating pressure is reached. Repair if defective.
	Discharge Temperature Switch Open	Cooling water temperature too high; increase water flow (water-cooled only).
		Cooling water flow insufficient; check water lines and valves (water-cooled only).
		Cooler plugged; clean tubes. If plugging persists, install water conditioner (water-cooled only).
		Cooling air flow restricted; clean cooler and check for proper ventilation.
		Ambient temperature is too high; provide sufficient ventilation.
Discharge Temperature Switch Open	Low fluid level; add fluid.	
	Clogged filter; change the fluid filter element and change the bearing filter element if maintenance indicator shows red.	
	Thermal valve not functioning properly; replace element.	
	Water flow regulating valve not functioning properly; change (water-cooled only).	
	Defective discharge temperature switch; check for a short or open circuit to probe and correct wiring.	

# Section 7

## MAINTENANCE

### TROUBLESHOOTING- STANDARD ELECTRO-MECHANICAL (CONTINUED)

SYMPTOM	PROBABLE CAUSE	REMEDY
COMPRESSOR WILL NOT BUILD FULL DISCHARGE PRESSURE.	Air Demand is Too Great	Check service lines for leaks or open valves up
	Dirty Air Filter	Check the filter indicator and inspect and/or change element if required.
	Pressure Regulator Out of Adjustment	Adjust regulator according to control adjustment instructions in the Maintenance section.
	Defective Pressure Regulator	Check diaphragm and replace if necessary (kit available).
LINE PRESSURE RISES ABOVE CUT-OUT PRESSURE SETTING ON PRESSURE SWITCH	Leak in Control System Causing Loss of Pressure Signals	Check for leaks.
	Defective Pressure Switch	Check that diaphragm and contacts are not damaged. Replace if necessary.
	Defective Regulator Valve	Check that air bleeds from control orifice when the pressure switch contacts open. Readjust; Repair or replace it if necessary (kit available).
	Plugged Control Line Strainer	Clean strainer (screen and o-ring replacement kit available).
	Defective Blowdown Valve	Check that sump pressure is exhausted to the atmosphere when the pressure switch contacts open. Repair or replace if necessary (kit available).
	High Pressure Shutdown Switch is Defective or Incorrectly Adjusted	Readjust or replace.
EXCESSIVE COMPRESSOR FLUID CONSUMPTION	Clogged Return Line or Orifice	Clean strainer (screen and o-ring replacement kit available). Clean orifice.
	Separator Element Damaged or Not Functioning Properly	Change separator.
	Leak in the Lubrication System	Check all pipes, connections and components.
	Excess Fluid Foaming	Drain and change.
	Fluid Level Too High	Drain and change.
PRESSURE RELIEF VALVE OPEN REPEATEDLY	Defective Pressure Relief Valve	Replace.
	Plugged Separator	Check separator differential.
LIQUID WATER IN COMPRESSED AIR LINES	Water Vapor Condensation from Cooling and Compression Occurs Naturally	Remove the water vapor from compressed air prior to distribution through the air system. Check operation of aftercooler and moisture separator. Install a compressed air dryer sized for the flow and dryness level required. (Note: Filters may also be required to remove particulates, liquid oil aerosols or for oil vapor removal. Change cartridges as recommended by the filter manufacturer). Check all drain traps routinely to insure their proper operation. Maintain them regularly.

#### 7.10 TROUBLESHOOTING- SUPERVISOR II

The information contained in the Supervisor II Troubleshooting chart is based upon both the actual applied situations and extensive testing at the factory. It

contains symptoms and usual causes for the described problems. However, **DO NOT** assume that these are the only problems that may occur. All available data concerning a problem should be systemati-

## Section 7 MAINTENANCE

cally analyzed before undertaking any repair or component replacement procedures.

A detailed visual inspection is worth performing for almost any problems which may prevent unnecessary damage to the compressor. Always remember to:

a. Check for loose wiring.

b. Check for damaged piping.

c. Check for parts damaged by heat or an electrical short circuit, usually apparent by discoloration or a burnt odor.

Should your problem persist after making the recommended check, consult your nearest Sullair representative or the Sullair Corporation factory.

### TROUBLESHOOTING - SUPERVISOR II

SYMPTOM (DISPLAY)	PROBABLE CAUSE	REMEDY
T1 HI Message	Discharge Temperature Exceeded 225_F (107_C) for Pre-Alarm Discharge Temperature Exceeded 235_F (113_C) for Shutdown Ambient Temperature Exceeded 105_F (41_C) Fluid Level in Sump is Too Low Thermal Valve Malfunctioned Cooler Fins are Dirty (Air-cooled only) Water Flow is Low (Water-cooled Packages Only) Water Temperature is High (Water-Cooled Packages Only) Cooler is Plugged (Water-Cooled Packages Only)	Improve local ventilation (i.e., remote intake of process and/or cooling air). Check/correct fluid level. Check/replace thermal valve. Clean cooler fins. Check cooling water supply (i.e., closed valves). Increase water flow, lower water temperature. Clean tubes and/or shell - if tube plugging persists, provide cleaner water.
T1 FAIL	Temperature RTD Malfunction	Check connections from RTD. If connection is good, replace RTD.
P1 HI Message	Discharge Pressure Exceeded Shutdown Level Because: P1 MAX-3psi (0.2 Bar) Exceeded for Pre-Alarm P1 MAX Exceeded for Shutdown Unloading Device (i.e., Blowdown Valve) Failed to Operate Pressure Regulator Adjusted Incorrectly Solenoid Valve Failed to Operate Control Air Signal Leaks Control Air Signal Filter Clogged	Check operation of unloading device. Check operation of pressure regulator. Check operation of solenoid valve. Check tubework feeding control signal for leaks. Service filter assembly.
P1, P2, P3 FAIL	Pressure Transducer Malfunction	Check connections from transducer. If connections are good, replace transducer.
P3 LOW	Oil Pressure Falls Below 10 psig (0.7 bar) or Less than 1/2 of P1 while Compressor is Running Because: Oil Filter Clogged Sump Oil Level Too Low	Replace filter element. Replenish oil level.
SEP MNTN Message	Plugged Separator nP1 > 10 psi (0.7 Bar)	Replace separator element. Check P1 & P2 pressure transducers.

# Section 7 MAINTENANCE

## TROUBLESHOOTING - SUPERVISOR II (CONTINUED)

SYMPTOM (DISPLAY)	PROBABLE CAUSE	REMEDY
COMPRESSOR DOES NOT BUILD FULL DISCHARGE PRESSURE	Air Demand Exceeds Supply	Check air service lines for open valves or leaks.
	Inlet Air Filter Clogged	Check for maintenance message on Supervisor display. Inspect and/or change element.
	Inlet Valve Not Fully Open	Check actuation and position.
	Pressure Sensor and/or Connections at Fault	Check connections from transducer. If adequate, replace transducer.
LINE PRESSURE RISES ABOVE UNLOAD SETTING	Pressure Sensor P2 at Fault	Check connections from transducer. If adequate, replace transducer.
	Unloading Device (i.e., Blowdown Valve) Failed to Operate	Check operation of unloading device.
	Solenoid Valve Failed to Operate	Check operation of solenoid valve.
	Control Air Signal Leaks	Check tubework feeding control signal for leaks.
	Control Air Signal Filter Clogged	Service filter assembly.
EXCESSIVE FLUID CONSUMPTION	Damaged or Improperly Gasketed Separator Element	Inspect separator element and gasket. Replace if damaged.
	Fluid System Leaks	Check tube/pipework for leaks.
	Fluid Level Too High	Drain excess fluid.
	Excessive Fluid Foaming	Drain and change fluid.
LIQUID WATER IN COMPRESSED AIR LINES	Water Vapor Condensation From Cooling and Compression Occurs Naturally	Remove the water vapor from compressed air prior to distribution through the air system. Check operation of aftercooler and moisture separator. Install a compressed air dryer sized for the flow and dryness level required. (Note: Filters may also be required to remove particulates, liquid oil aerosols or for oil vapor removal. Change cartridges as recommended by the filter manufacturer). Check all drain traps routinely to insure their proper operation. Maintain them regularly.

### NOTE ON TRANSDUCERS:

Whenever a sensor is suspected of fault, the recommended cause of action is to measure the signal (pressure, temperature, etc.) with an alternate calibrated instrument and compare readings. If readings conflict, the electrical and/or tubing connections should be inspected, and if no faults are evident, then replace the sensor and re-evaluate against the calibrated instrument.

### 7.11 CALIBRATION

The Supervisor II has software calibration of the pressure and temperature probes. This calibration affects the offset but not the slope of the pressure and temperature calculations. Because of this, the most accurate method is to heat or pressurize the transducer to its operating value. If this is too difficult, room temperature/open atmosphere calibration is

adequate. Calibration may only be done while machine is stopped and unarmed.

To enter calibration mode, you must press the following keys in sequence while in the default status display mode: "⊕", "Y", DSP, "B ✕", PRG. Once in calibration mode, you will see a screen like the following:

CAL	P1
0	97

In the above example, "0" refers to the amount of adjustment (in psi or \_F, "97" refers to the current value of P1).

To make adjustments, Press the "Y" (UP ARROW) key to increase the value, press the "B ✕" (DOWN ARROW / LAMP TEST) key to decrease the value. The number on the left will increase or decrease al-

## Section 7

# MAINTENANCE

ways showing the total amount of adjustment. Maximum adjustment is  $\pm 7$ .

The **DSP** key exits, wiping out changes to the current item, while saving changes to any previous items. The **PRG** key saves the current item and advances to the next. All temperatures and pressures may be calibrated individually.

# Section 7 MAINTENANCE

Figure 7-7 Piping and Instrumentation Diagram – Standard

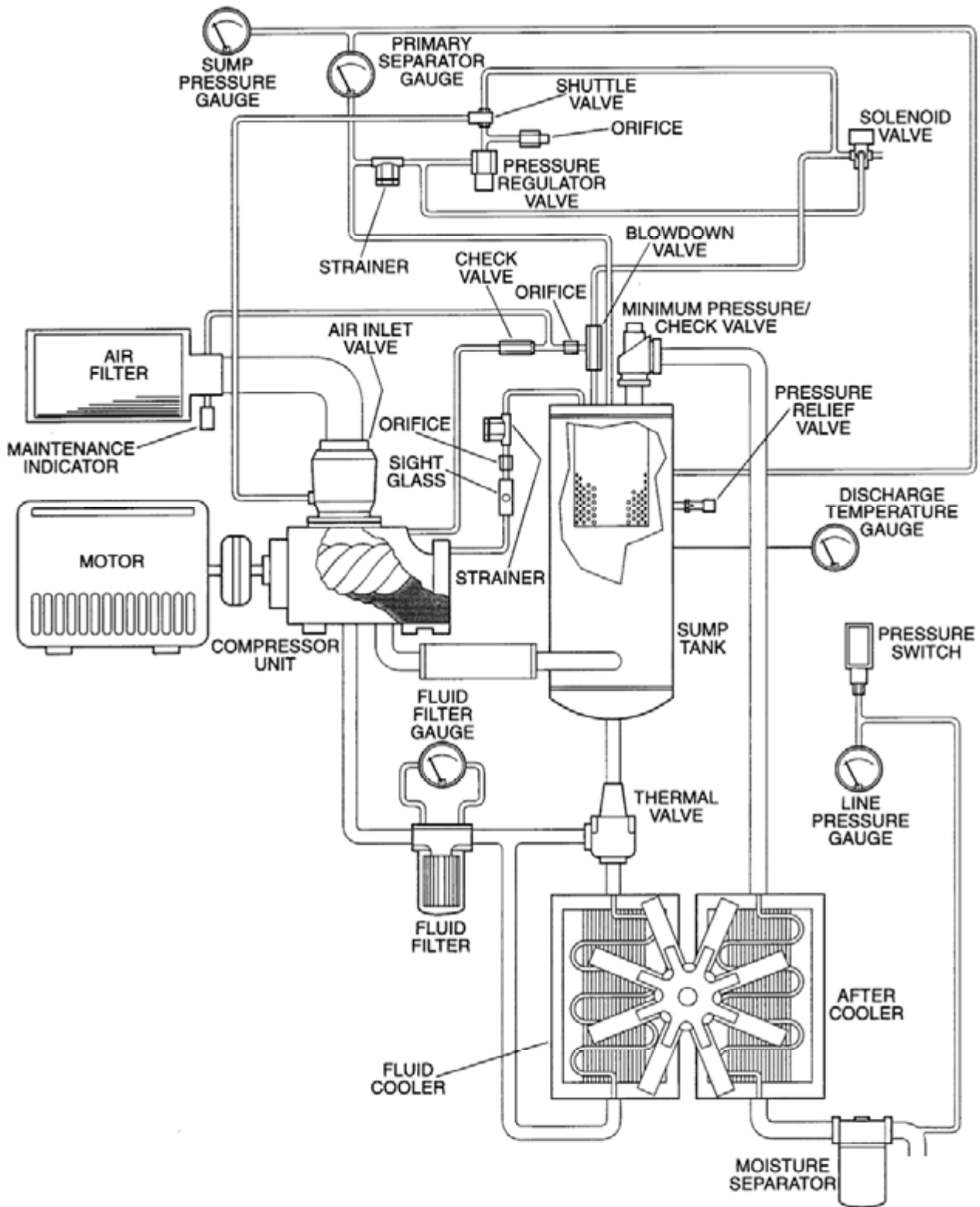
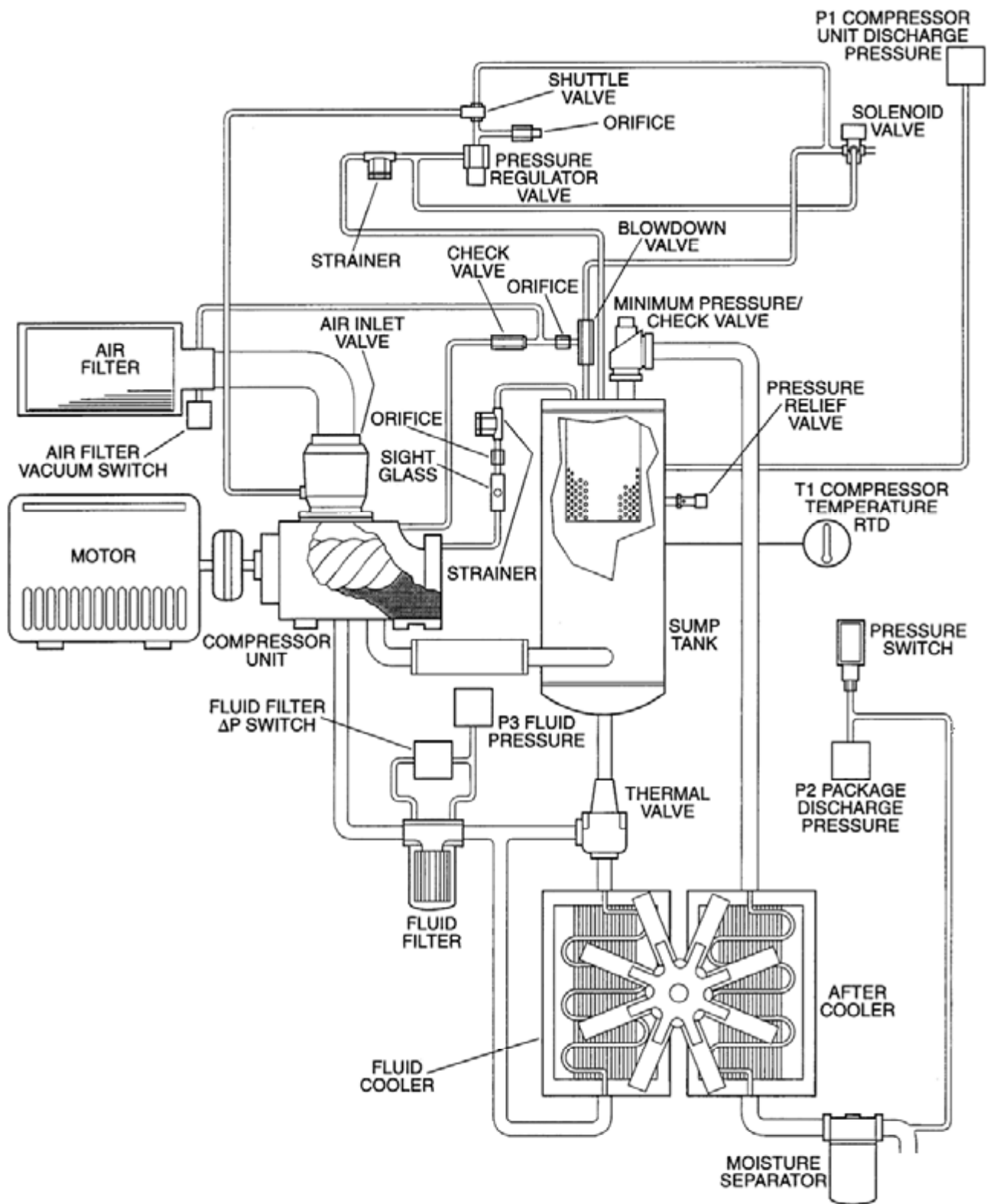


Figure 7-8 Piping and Instrumentation Diagram – Supervisor II



# NOTES

# ILLUSTRATIONS AND PARTS LIST

## 8.1 PROCEDURE FOR ORDERING PARTS

Parts should be ordered from the nearest Sullair Representative or the Representative from whom the compressor was purchased. If for any reason parts cannot be obtained in this manner, contact the factory directly at the addresses, phone or fax numbers listed below.

When ordering parts always indicate the **Serial Number** of the compressor. This can be obtained from the Bill of Lading for the compressor or from the Serial Number Plate located on the compressor.

**SULLAIR ASIA, LTD.**  
Sullair Road, No. 1  
Chiwan, Shekou  
Shenzhen, Guangdong PRV.  
PRC POST CODE 518068  
Telephone: 755-6851686  
Fax: 755-6853473

**SULLAIR EUROPE, S.A.**  
Zone Des Granges BP 82  
42602 Montbrison Cedex, France  
Telephone: 33-477968470  
Fax: 33-477968499

**SULLAIR CORPORATION**  
3700 East Michigan Boulevard  
Michigan City, Indiana 46360 U.S.A.  
Telephone: 1-219-879-5451  
Fax: (219) 874-1273  
Fax: (219) 874-1835 (Parts)  
Fax: (219) 874-1288 (Service)

## 8.2 RECOMMENDED SPARE PARTS LIST

DESCRIPTION	KIT NUMBER	QTY
element, compressor fluid filter 02250096-783	250025-525	1
element, heavy duty air filter 02250107-327 (25-30HP/ 19-22KW)	043334	1
element, heavy duty air filter 040595 (40HP/ 30 KW)	040596	1
element, primary replacement for separator 250034-113	250034-114	1
kit, repair for air inlet valve 02250088-348	250019-451	1
kit, repair springs for air inlet valve 02250088-348	250029-315	1
kit, repair for minimum pressure/check valve 02250097-609	02250110-988	1
kit, repair cap for minimum pressure/check valve 02250097-609	02250046-397	1
kit, repair o-ring for minimum pressure/check valve 02250097-609	02250048-362	1
kit, repair piston for minimum pressure/check valve 02250097-609	02250051-338	1
kit, repair thermal valve 02250096-738 (170_F)	250025-621	1
kit, repair thermal valve 02250103-509 (190_F)	02250103-562	1
kit, repair for pressure regulator 250017-280	250019-453	1
kit, repair for blowdown valve 250025-655	250031-772	1
kit, repair for solenoid valve 250038-674 (<= 140 psi/ 9.7 bar)	250038-673	1
kit, replacement for solenoid valve coil 250038-674 (<= 140 psi/ 9.7 bar)	250031-738	1
kit, repair for solenoid valve 250038-675 (>140 psi/ 9.7 bar)	02250055-939	1
kit, replacement for solenoid valve coil 250038-675 (>140 psi/ 9.7 bar)	250038-730	1
kit, repair inlet valve 02250088-348	250019-451	1
kit, repair for v-type strainer 241771	241772	1
kit, repair for shaft seal	001836-007	1
element, replacement for combination separator/trap 02250078-841	02250081-108	1
kit, repair automatic drain for combination separator/trap 02250078-841	02250087-422	1
manual, Sequencing & Protocol (I)	02250057-696	1
fluid, SRF 1/4000 (5 gallons)	250019-662	(II)
lubricant, Sullube (std.) (5 gallons)	250022-669	(II)
lubricant, 24 KT (5 gallons)	046850-001	(II)

(I) This document is required to program your personal computer to communicate with the Supervisor II panel.

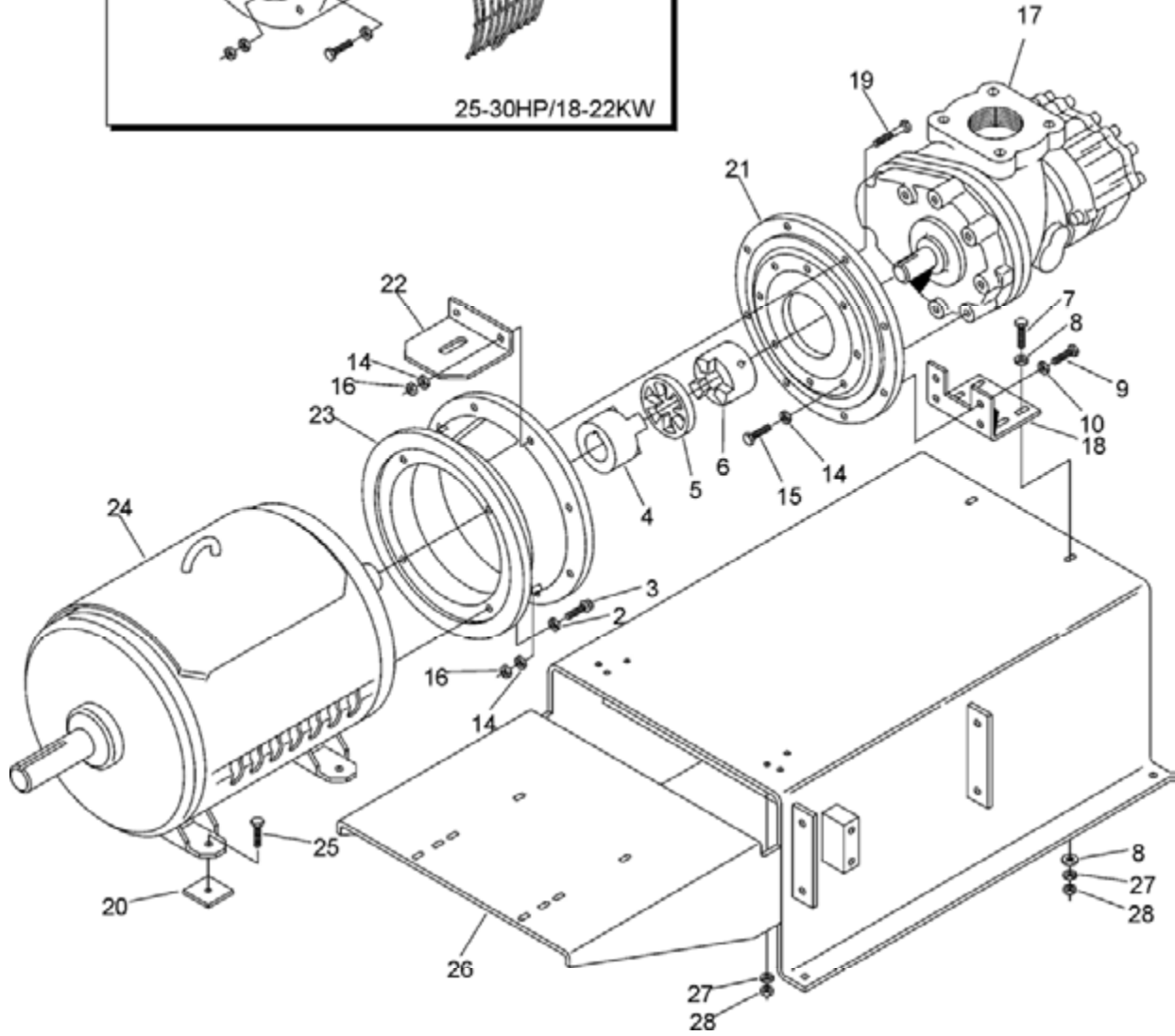
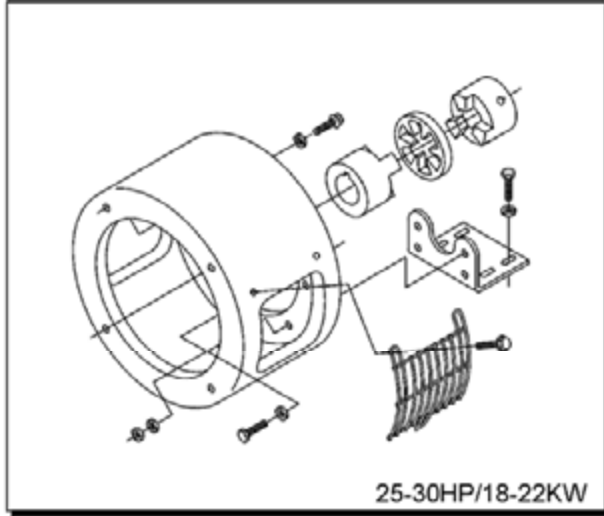
(II) For proper amount of fluid fill, please consult Lubrication Guide in Section 3, Specifications.

**PLEASE NOTE: WHEN ORDERING PARTS, ALWAYS INDICATE SERIAL NUMBER OF COMPRESSOR**

Section 8

# ILLUSTRATIONS AND PARTS LIST

## 8.3 MOTOR, COMPRESSOR, FRAME AND PARTS



# ILLUSTRATIONS AND PARTS LIST

## 8.3 MOTOR, COMPRESSOR, FRAME AND PARTS

<i>key number</i>	<i>description</i>	<i>part number</i>	<i>quantity</i>
1	adapter, motor (25, 30HP)	250038-448	1
2	washer, springlock reg pltd 1/2" (25, 30HP)	837808-125	4
3	Swasher, springlock reg pltd 5/8"(40HP) capscrew, ferry head 1/2"-13 x 1-1/4" (25, 30HP)	837810-156	4
	capscrew, ferry head 5/8"-11 x 1-1/4" (40HP)	867308-125	4
4	hub, motor (25, 30HP)	867310-150	4
	Shub, motor (40HP)	045671	1
5	element, drive coupling (25, 30HP)	250004-640	1
	Selement, drive coupling (40HP)	045672	1
6	coupling, hub (25, 30HP)	250004-638	1
	Scoupling, hub (40HP)	045673	1
7	capscrew, hex gr5 1/2-13 x 1-1/2"	250004-639	1
8	washer, pl-b reg plated 1/2"	829108-150	2
9	capscrew, hex gr5 3/8"-16 x 2"	838208-112	4
10	washer, pl-b reg plated 3/8"	829106-200	2
11	angle, compressor mounting	838206-112	2
12	screw, ser washer 5/16" x 3/4"	02250103-594	1
13	grille, coupling guard	829705-075	6
14	washer, springlock reg plated 3/8" (25, 30HP)	250038-863	2
	Swasher, springlock reg plated 3/8" (40HP)	837806-094	9
15	capscrew, hex gr5 3/8"-16 x 1-1/4"	837806-094	12
16	nut, hex plated 3/8"-16 (25, 30HP)	829106-125	7
	wnut, hex plated 3/8"-16 (40HP)	825206-337	2
17	compressor unit	825206-337	5
18	angle, compressor mounting	consult factory	1
19	capscrew, hex gr5 3/8"-16 x 1-3/4"	02250107-610	1
		829106-175	3

(Continued on page 53)

- (I) There is an exchange program whereby a remanufactured compressor unit can be obtained from Sullair distributors or the factory at less cost than the owner could repair the unit. For information regarding the unit exchange program, contact your nearest Sullair representative or the Sullair Corporation.

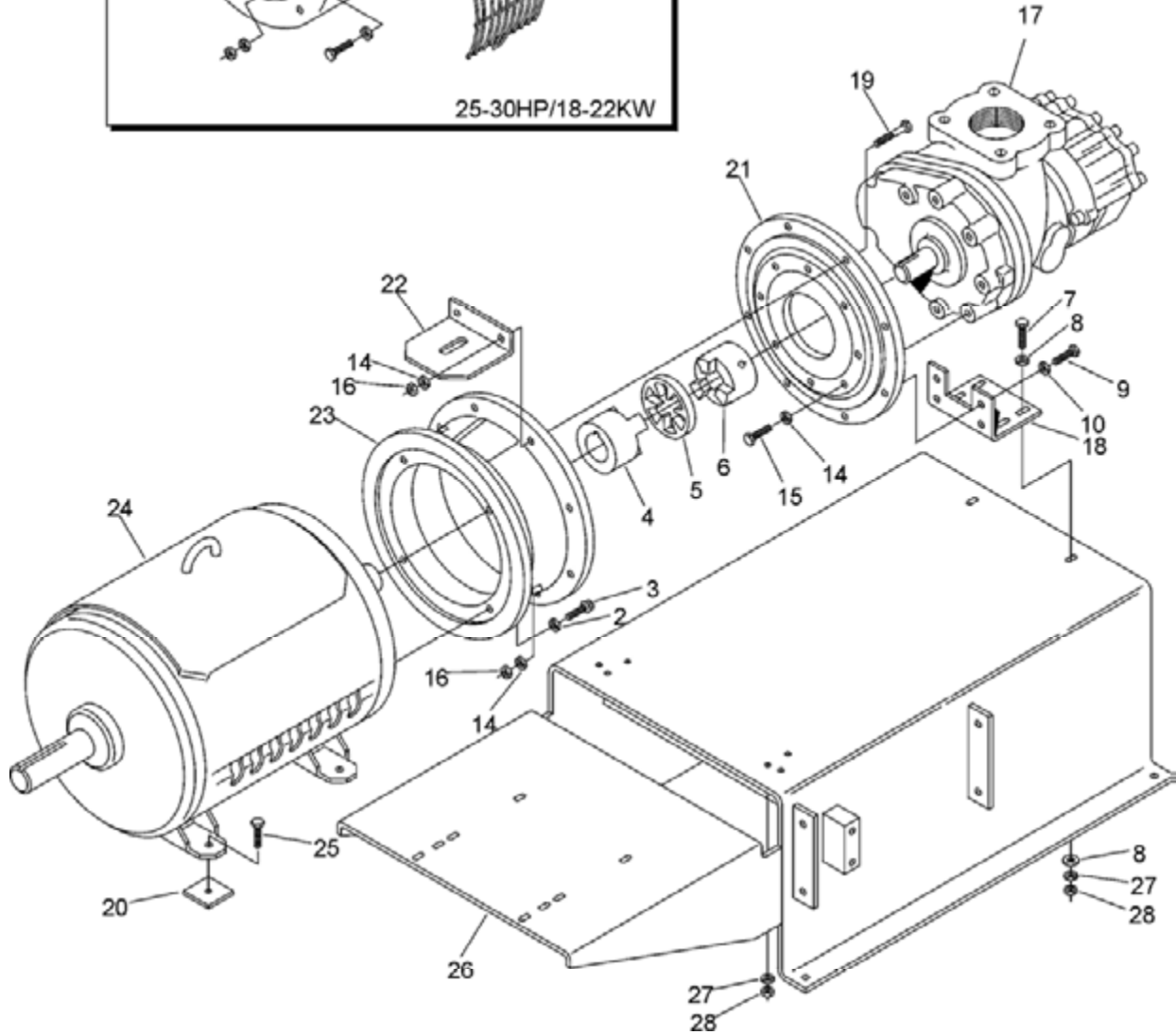
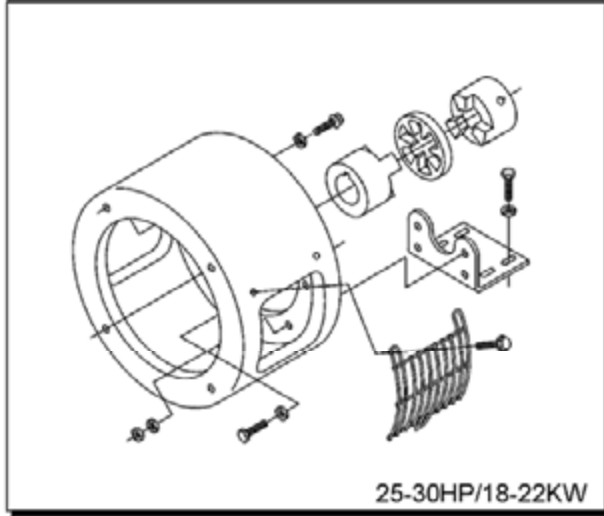
The shaft seal is not considered part of the compressor unit in regard to the two year warranty. The normal Sullair parts warranty applies. For shaft seal repairs, order shaft seal repair kit no. 001836-007.

**PLEASE NOTE: WHEN ORDERING PARTS, INDICATE SERIAL NUMBER OF COMPRESSOR**

Section 8

# ILLUSTRATIONS AND PARTS LIST

## 8.3 MOTOR, COMPRESSOR, FRAME AND PARTS



# ILLUSTRATIONS AND PARTS LIST

---

## 8.3 MOTOR, COMPRESSOR, FRAME AND PARTS (CONTINUED)

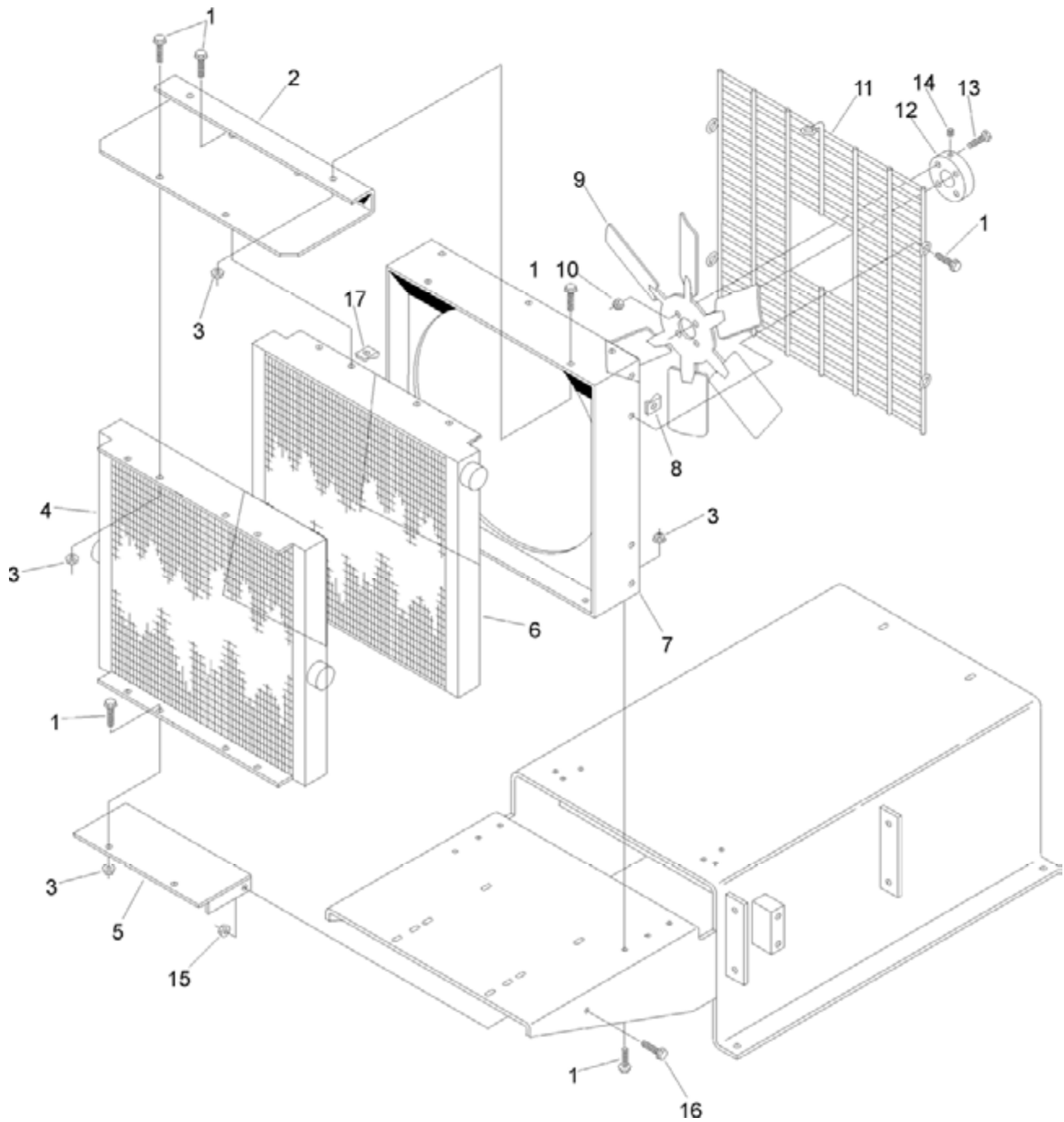
<i>key number</i>	<i>description</i>	<i>part number</i>	<i>quantity</i>
20	block, spacer 1 x 2 x 3 (25,30HP)	250001-798	2
21	adapter, compressor (40HP)	250009-542	1
22	plate, motor/compressor	225980	1
23	adapter, motor (40HP)	231977	1
24	motor	consult factory	1
25	capscrew, hex gr5 1/2"-13 x 2-3/4" (25, 30HP)	829108-275	2
	Scapscrew, hex gr5 1/2"-13 x 1-3/4" (40HP)	829108-175	2
26	frame	02250097-328	1
27	washer, springlock reg plated 1/2"	837808-125	4
28	nut, hex plated 1/2"-13	825208-448	4
29	sign, warning sever fan	049855	2

---

**PLEASE NOTE: WHEN ORDERING PARTS, INDICATE SERIAL NUMBER OF COMPRESSOR**

# Section 8 ILLUSTRATIONS AND PARTS LIST

## 8.4 COOLER ASSEMBLY



# ILLUSTRATIONS AND PARTS LIST

---

## 8.4 COOLER ASSEMBLY

<i>key number</i>	<i>description</i>	<i>part number</i>	<i>quantity</i>
1	screw, ser washer 5/16"-18 x 3/4"	829705-075	17
2	panel, cooler adapter (25, 30HP)	02250107-473	1
	Spanel, cooler adapter (40HP)	02250107-548	1
3	nut, hex flanged plated 5/16"-18	825305-283	8
4	cooler, fluid ls-10 1-1/16" SAE	02250096-704	1
5	plate, cooler mtg frame extension	02250105-536	1
6	cooler, air/aftercooler (25, 30HP)	407106	1
	Scooler, air/aftercooler (40HP)	250006-931	1
7	shroud, fan-17" (25, 30HP)	011994	1
	wshroud, fan-18" (40HP)	013315	1
8	nut, retainer-u 5/16"-18 .140	861505-140	5
9	fan, 18" dia rh blower (25, 30HP)	042492	1
	wfan, 17" dia rh blower (40HP)	249012	1
10	nut, hex locking plated 5/16"-18 (25, 30HP)	825505-166	4
	Snut, hex locking plated 3/8"-16 (40HP)	825506-198	4
11	guard, fan shroud	225962	1
12	hub, fan mounting (25, 30HP)	023350	1
	S hub, fan mounting (40HP)	231981	1
13	capscrew, ferry head 5/16"-18 x 1-1/2" (25, 30HP)	828405-150	4
	Scapscrew, ferry head 3/8"-16 x 1-3/4" (40HP)	828406-175	4
14	screw, set 5/16"-18 x 1/2"	250010-322	2
15	nut, hex flanged plated 5/16"-18	825305-283	2
16	screw, ser washer 5/16"-18 x 3/4"	829705-075	2
17	nut, retainer-u 5/16"-18	861505-140	4

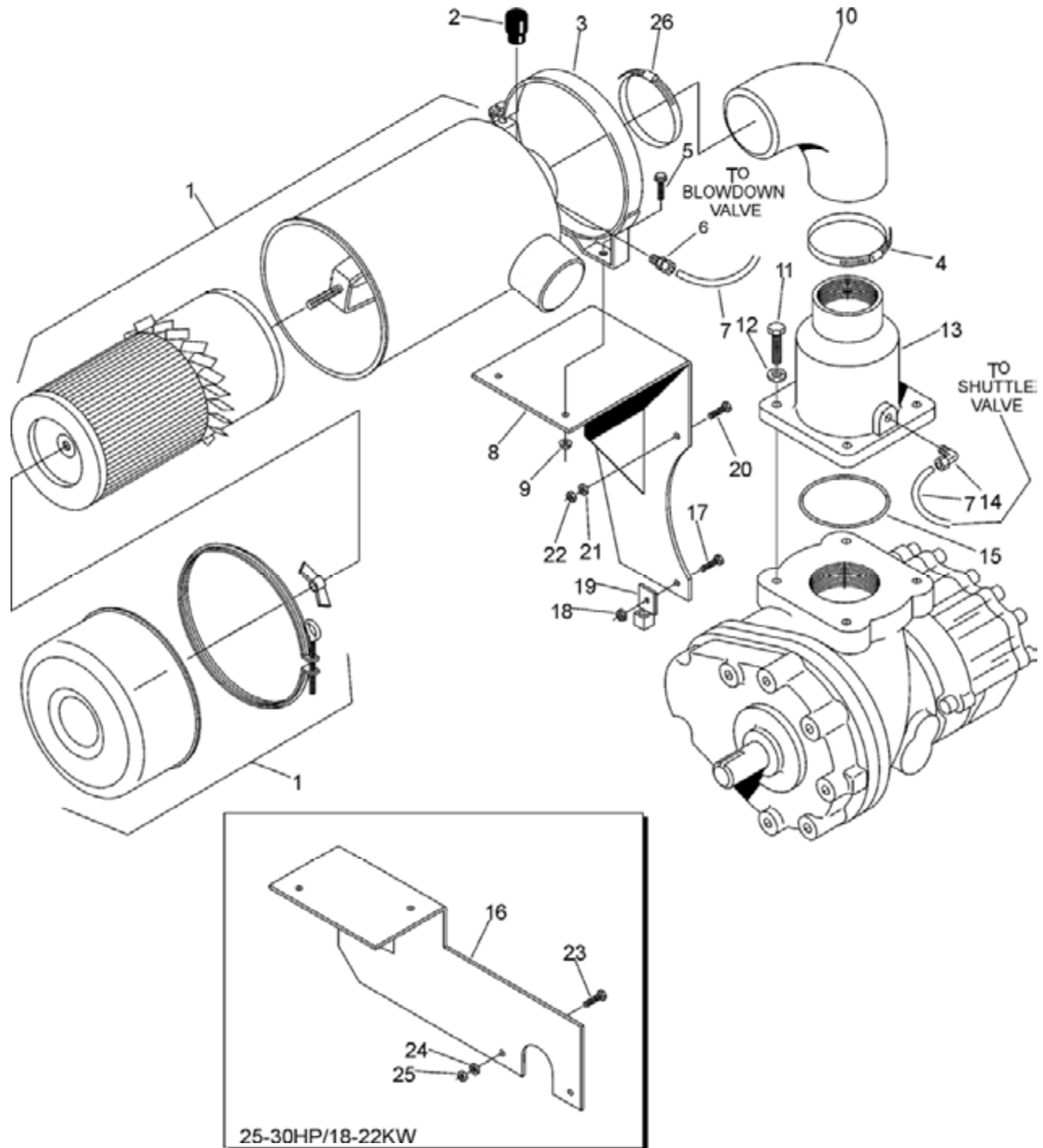
---

**PLEASE NOTE: WHEN ORDERING PARTS, INDICATE SERIAL NUMBER OF COMPRESSOR**

# Section 8

## ILLUSTRATIONS AND PARTS LIST

### 8.5 AIR INLET SYSTEM



# ILLUSTRATIONS AND PARTS LIST

## 8.5 AIR INLET SYSTEM

<i>key number</i>	<i>description</i>	<i>part number</i>	<i>quantity</i>
1	filter, air inlet heavy duty (25, 30HP) <b>(I)</b>	02250107-327	1
	wfilter, air inlet heavy duty (40HP) <b>(II)</b>	040595	1
2	indicator, maintenance	045757	1
3	band, mounting-inlet filter (25, 30HP)	043370	1
	Sband, mounting-inlet filter (40HP)	040598	1
4	clamp, inlet elbow	250018-550	1
5	screw, ser washer 5/16"-18 x 3/4"	829705-075	2
6	connector, 1/4"tube x 1/8"npt	250018-427	1
7	tubing, nylon 1/4" black	02250054-861	-
8	support, filter heavy duty	02250100-529	1
9	nut, hex flanged plated 5/16"-18	825305-283	2
10	elbow, rubber 90_ red 2-1/2" x 3" (25, 30HP)	250032-462	1
	Selbow, rubber 90_ 3" (40HP)	040599	1
11	capscrew, hex gr5 5/8"-11 x 1-1/2"	829110-150	4
12	washer, springlock reg plated 5/8"	837810-156	4
13	valve, inlet control <b>(III)</b>	02250088-348	1
14	elbow, 1/4"tube x 1/4"npt	250018-430	1
15	o-ring, viton	826502-238	1
16	support, filter heavy duty	02250100-528	1
17	capscrew, hex gr5 5/16"-18 x 1-3/4"	829105-175	1
18	nut, hex flanged plated 5/16"-18	825305-283	1
19	lug, scrulug-ground	849215-025	1
20	capscrew, hex gr5 3/8"-16 x 1-3/4"	829106-175	1
21	washer, springlock reg plated 3/8"	837806-094	1
22	nut, hex plated 3/8"-16	825206-337	1
23	capscrew, hex gr5 3/8"-16 x 1-1/2"	829106-150	2
24	washer, springlock reg plated 3/8"	837806-094	2
25	nut, hex plated 3/8"-16	825206-337	2
26	clamp, inlet elbow (25, 30HP)	040083	1
	Sclamp, inlet elbow (40HP)	250018-550	1

**(I)** For maintenance on air filter no. 02250107-327, order replacement element no. 043334.

**(II)** For maintenance on air filter no. 040595, order replacement element no. 040596.

**(III)** For maintenance on air inlet valve no. 02250088-348, order repair kit no. 250019-451, and/or repair kit for springs no. 250029-315.

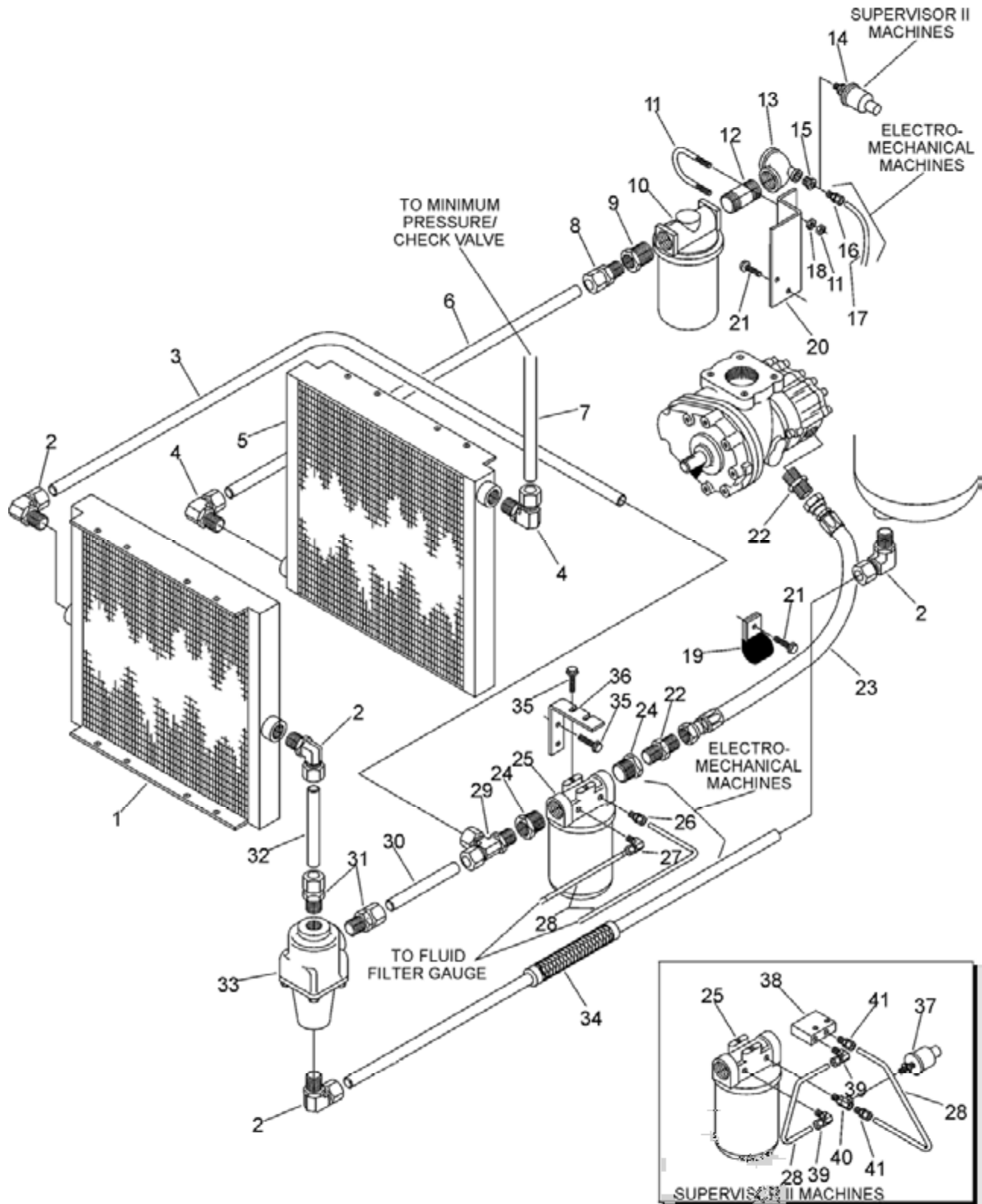
---

**PLEASE NOTE: WHEN ORDERING PARTS, INDICATE SERIAL NUMBER OF COMPRESSOR**

Section 8

# ILLUSTRATIONS AND PARTS LIST

## 8.6 COOLING AND LUBRICATION SYSTEM- AIR-COOLED



# ILLUSTRATIONS AND PARTS LIST

## 8.6 COOLING AND LUBRICATION SYSTEM- AIR-COOLED

<i>key number</i>	<i>description</i>	<i>part number</i>	<i>quantity</i>
1	cooler, fluid ls-10 1-1/16" SAE	02250096-704	1
2	elbow, tube straight thread 3/4" x 1-1/16"	811612-106	4
3	tube, 3/4" cooler/fluid filter	02250099-370	1
4	elbow, tube-m 1" x 3/4" (25, 30HP)	810516-075	2
	Selbow, tube-m 1" x 1" (40HP)	810516-100	2
5	cooler, air/aftercooler (25, 30HP)	407106	1
	Scooler, air/aftercooler (40HP)	250006-931	1
6	tube, aftercooler/moisture separator	02250100-730	1
7	tube, minimum pressure valve/aftercooler	02250099-372	1
8	connector, tube-m 1" x 1"	810216-100	1
9	bushing, reducing hex 1-1/2" x 1" plated	868906-040	1
10	separator, moisture 1-1/2"npt (I)	02250078-841	1
11	U-bolt, 3/8" x 1-1/2" pipe plated	868306-150	1
12	nipple, pipe xs 1/2" x 4"	866424-040	1
13	tee, reducing 1-1/2" x 1/2" x 1-1/2" plated	867506-026	1
14	transducer, pressure 0-250psi 1-5dvc N4	02250078-933	1
15	bushing, reducing 1/2" x 1/8" plated	868902-005	1
16	connector, tube-m 1/4" x 1/8" nylon	250018-427	1
17	tubing, nylon 1/4" black	02250054-861	-
18	washer, springlock reg plated 3/8"	837806-094	2
19	clamp, tube rubber center 1-3/8" dia	2500025-638	1
20	support, bracket moisture separator ls10	02250100-634	1
21	screw, ser washer 5/16"-18 x 3/4"	829705-075	3
22	connector, SAE x ORFS 0.75"	02250099-765	2
23	hose, mp ORFS f-swivel end .75" x 45"	02250099-175	1
24	reducer, straight thread 1-1/4" x 3/4" viton	870020-012	2
25	filter, fluid 1-5/8" SAE connection (II)	02250096-783	1
26	connector, tube 1/8M x 1/4T stainless steel	250139-024	1
27	elbow, tube 1/8M x 1/4T stainless steel	250211-013	1
28	tubing, stainless steel 1/4" 20ga	841215-004	-
29	tee, tube-run straight thread 3/4" x 1-1/16"	811912-106	1
30	tube, fluid filter/thermal valve	02250099-367	1
31	connector, tube straight thread 3/4" x 1-1/16"	811812-106	2
32	tube, thermal valve/oil cooler	02250099-369	1

(Continued on page 61)

(I) For maintenance on moisture separator no. 02250078-841, order replacement element no. 02250081-108, and automatic drain no. 02250087-422.

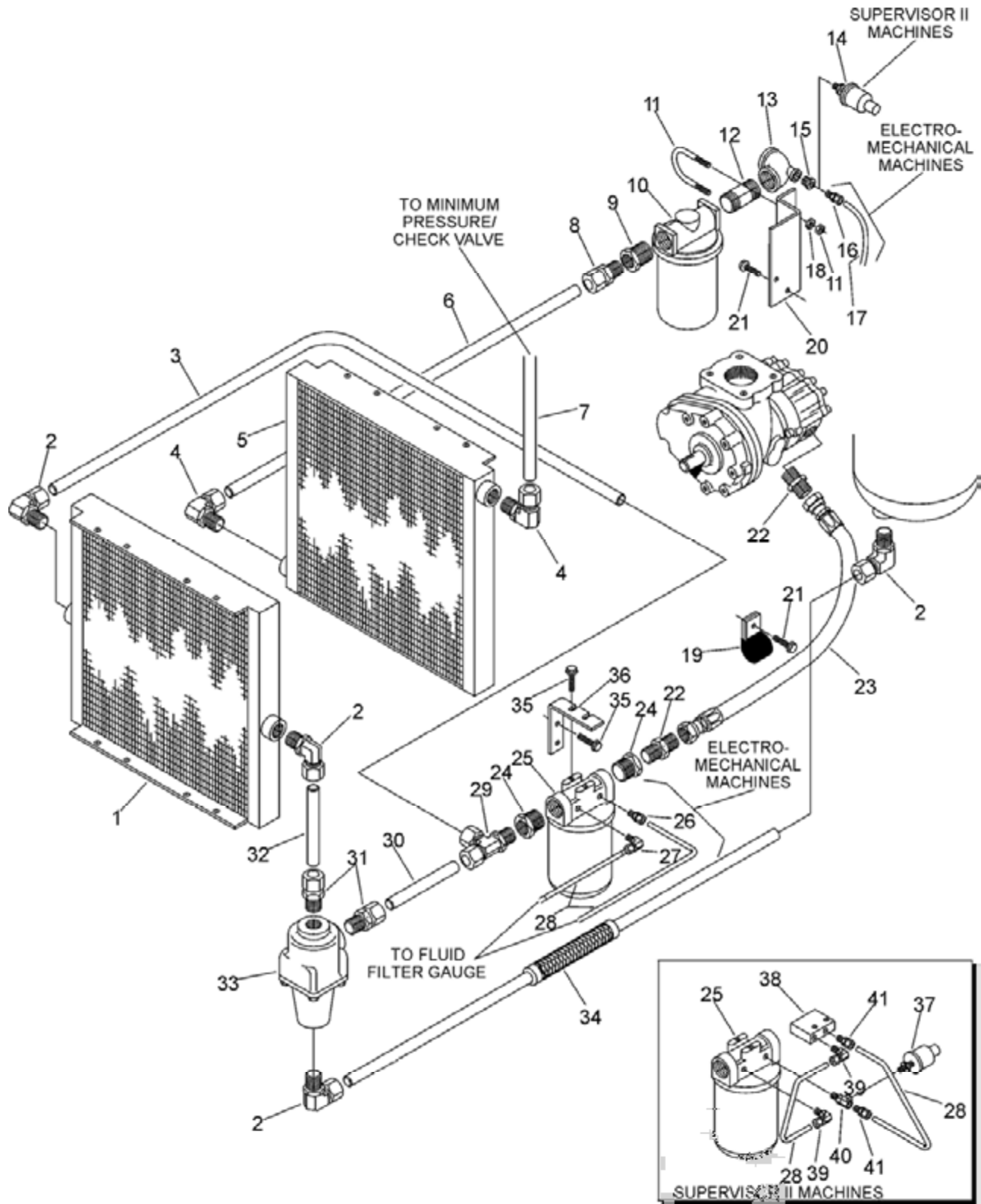
(II) For maintenance on fluid filter no. 02250096-783, order replacement element no. 250025-525.

**PLEASE NOTE: WHEN ORDERING PARTS, INDICATE SERIAL NUMBER OF COMPRESSOR**

Section 8

# ILLUSTRATIONS AND PARTS LIST

## 8.6 COOLING AND LUBRICATION SYSTEM- AIR-COOLED



# ILLUSTRATIONS AND PARTS LIST

---

## 8.6 COOLING AND LUBRICATION SYSTEM- AIR-COOLED (CONTINUED)

<i>key number</i>	<i>description</i>	<i>part number</i>	<i>quantity</i>
33	valve, thermal (170_F) <b>(III)</b>	02250096-738	1
	Svalve, thermal (190_F) <b>(IV)</b>	02250103-509	1
34	tube, flexible tank/thermal valve ls10	02250100-616	1
35	screw, ser washer 5/16"-18 x 3/4"	829705-075	4
36	support, bracket oil filter	02250103-970	1
37	transducer, pressure 0-250psi 1-5dvc N4	02250078-933	1
38	switch, pressure differential 20psid	02250050-154	1
39	elbow, tube 1/8"M x 1/4"T stainless steel	250211-013	2
40	tee, tube 1/8F x 1/8M x 1/8F	02250077-903	1
41	connector, tube 1/8"M x 1/4"T stainless steel	250139-024	2

**(III)** For maintenance on thermal valve (170\_F) no. 02250096-738, order repair kit no. 250025-621.

**(IV)** For maintenance on thermal valve (190\_F) no. 02250103-509, order repair kit no. 02250103-562.

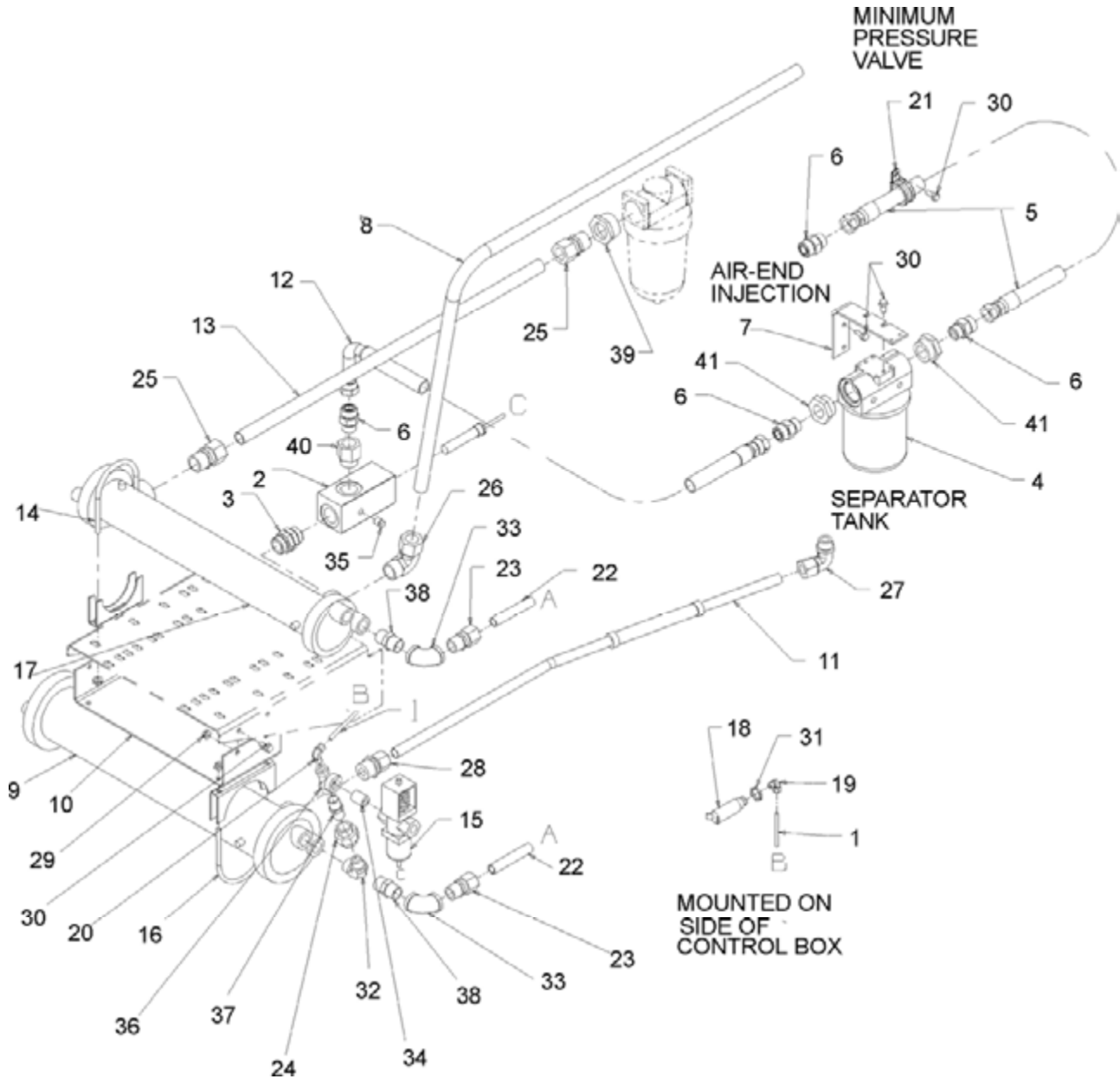
---

**PLEASE NOTE: WHEN ORDERING PARTS, INDICATE SERIAL NUMBER OF COMPRESSOR**

Section 8

# ILLUSTRATIONS AND PARTS LIST

## 8.7 COOLING AND LUBRICATION SYSTEM- WATER-COOLED 25 & 30HP/ 18 & 22KW



# ILLUSTRATIONS AND PARTS LIST

## 8.7 COOLING AND LUBRICATION SYSTEM- WATER-COOLED 25 & 30HP/ 18 & 22KW

<i>key number</i>	<i>description</i>	<i>part number</i>	<i>quantity</i>
1	tube,nylon .25"od x .04w black	02250054-861	4 ft
2	tee,sae/npt oil return	02250085-979	1
3	adapter, sae 1 5/16 x 1 5/16-12	02250086-022	1
4	filter, fluid 1 5/8 sae str thrd con <b>(I)</b>	02250096-783	1
5	hose, medium pressure orfs f-swvl end 45"long	02250099-175	1
6	connector,sae x orfs 0.75"	02250099-765	4
7	support, bracket oil filt ls-10 l.f.	02250103-970	1
8	tube,1"od clr/tank 25/30hp	02250110-168	1
9	cooler, heat exchanger std sae ports	02250110-238	1
10	support, bracket w.o.clr ls-10-lf	02250110-454	1
11	tube, flexible tank/w.o.c. 3/4"	02250110-456	1
12	hose, medium pressure orfs f-swvl 3/4"x 31" 90	02250113-370	1
13	tube,wc/moist sep ls10	02250113-436	1
14	clamp, exhaust 3 1/2"	040284	2
15	valve, water regulator 1/2"	041265	1
16	clamp, exhaust 4 1/2"	041983	2
17	heat exchanger, 3 x 24 25/30hp	043096	1
18	switch, pressure n.o. 10 psi	250017-992	1
19	elbow, 90 1/4t pls x 1/8 npt m	250018-429	1
20	elbow, 90 1/4t pls x 1/4 npt m	250018-430	1
21	clamp, tube rubber 1-3/8"F	250025-638	1
22	tubing, nylon 3/4"od	250039-353	3 ft
23	connector,male plastic tubing 3/4" x 3/4	250039-357	2
24	union, pipe galv 1/2	802315-020	1
25	connector, tube-m 1 x 1	810216-100	2
26	elbow, tube 90 deg m 1 x 1	810516-100	1
27	elbow, tube str thrd 3/4 x 1 1/16	811612-106	1
28	connector, tube str thd 3/4 x 1 5/16	811812-116	1
29	nut,hex f pltd 5/16-18	825305-283	4
30	screw, hex ser washer 5/16-18 x 3/4	829705-075	9
31	locknut, conduit 1/2"	847200-050	1
32	elbow, pipe-90m 3/4 x 1/2	860512-050	1
33	elbow, pipe 90 deg plt 3/4"	866215-030	2
34	nipple,pipe-xs plt 1/2 x cl	866408-000	1
35	plug, pipe 1/4" 3000# stl plt	866900-010	1

(Continued on page 65)

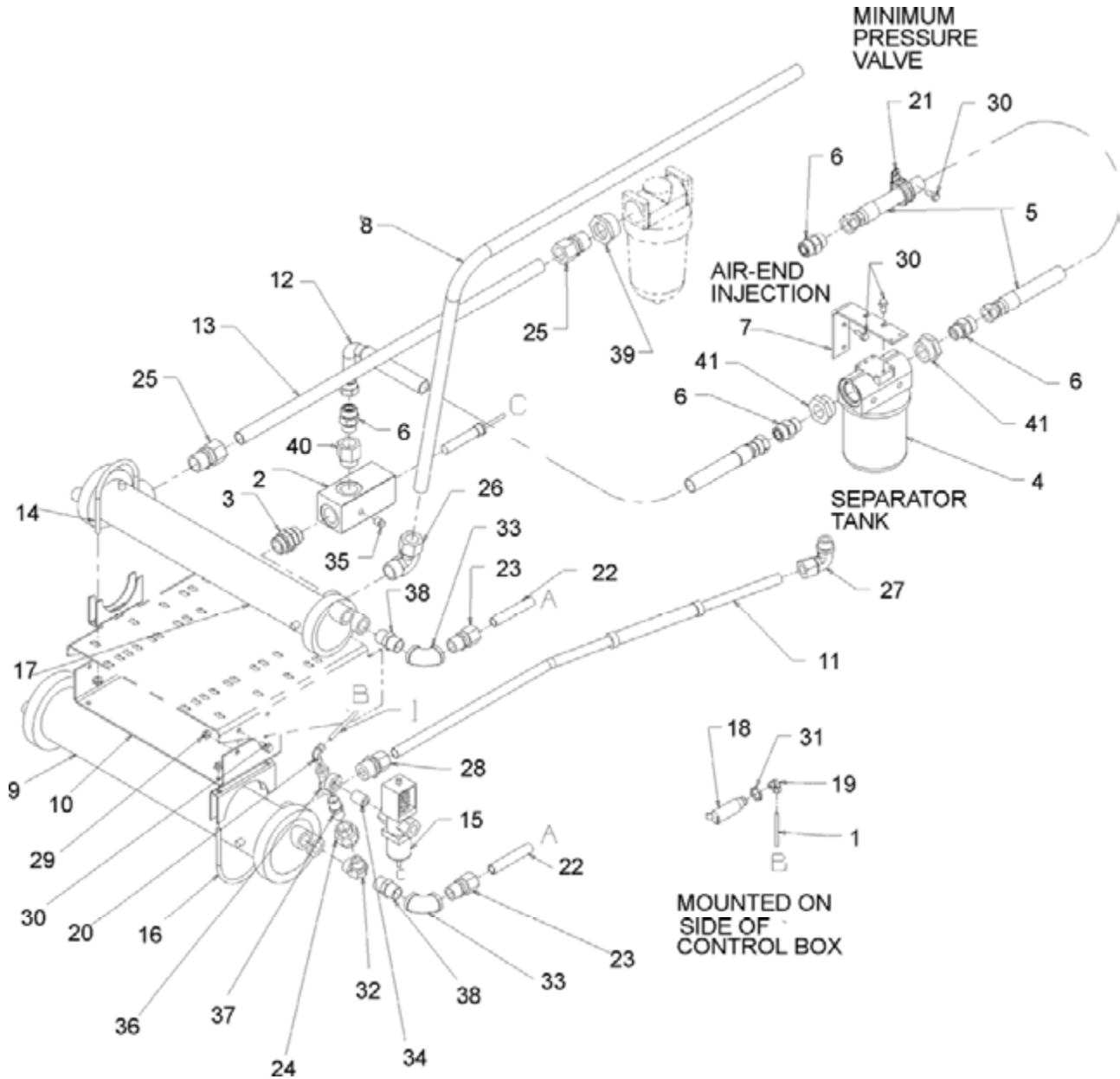
(I) For maintenance on fluid filter no. 02250096-783, order replacement element no. 250025-525.

**PLEASE NOTE: WHEN ORDERING PARTS, INDICATE SERIAL NUMBER OF COMPRESSOR**

Section 8

# ILLUSTRATIONS AND PARTS LIST

## 8.7 COOLING AND LUBRICATION SYSTEM- WATER-COOLED 25 & 30HP/ 18 & 22KW



## ILLUSTRATIONS AND PARTS LIST

---

### 8.7 COOLING AND LUBRICATION SYSTEM- WATER-COOLED 25 & 30HP/ 18 & 22KW (CONTINUED)

<i>key number</i>	<i>description</i>	<i>part number</i>	<i>quantity</i>
36	tee, reducing pltd 1/2 x 1/4 x 1/2	867502-012	1
37	nipple,pipe-hx pltd 1/2 x 1/2	868508-050	1
38	nipple,pipe-hx pltd 3/4 x 3/4	868512-075	2
39	bushing,red hex pltd 1 1/2 x 1	868906-040	1
40	reducer,str thrd viton 1 x 3/4	870016-012	1
41	reducer,str thrd viton 1 1/4 x 3/4	870020-012	2

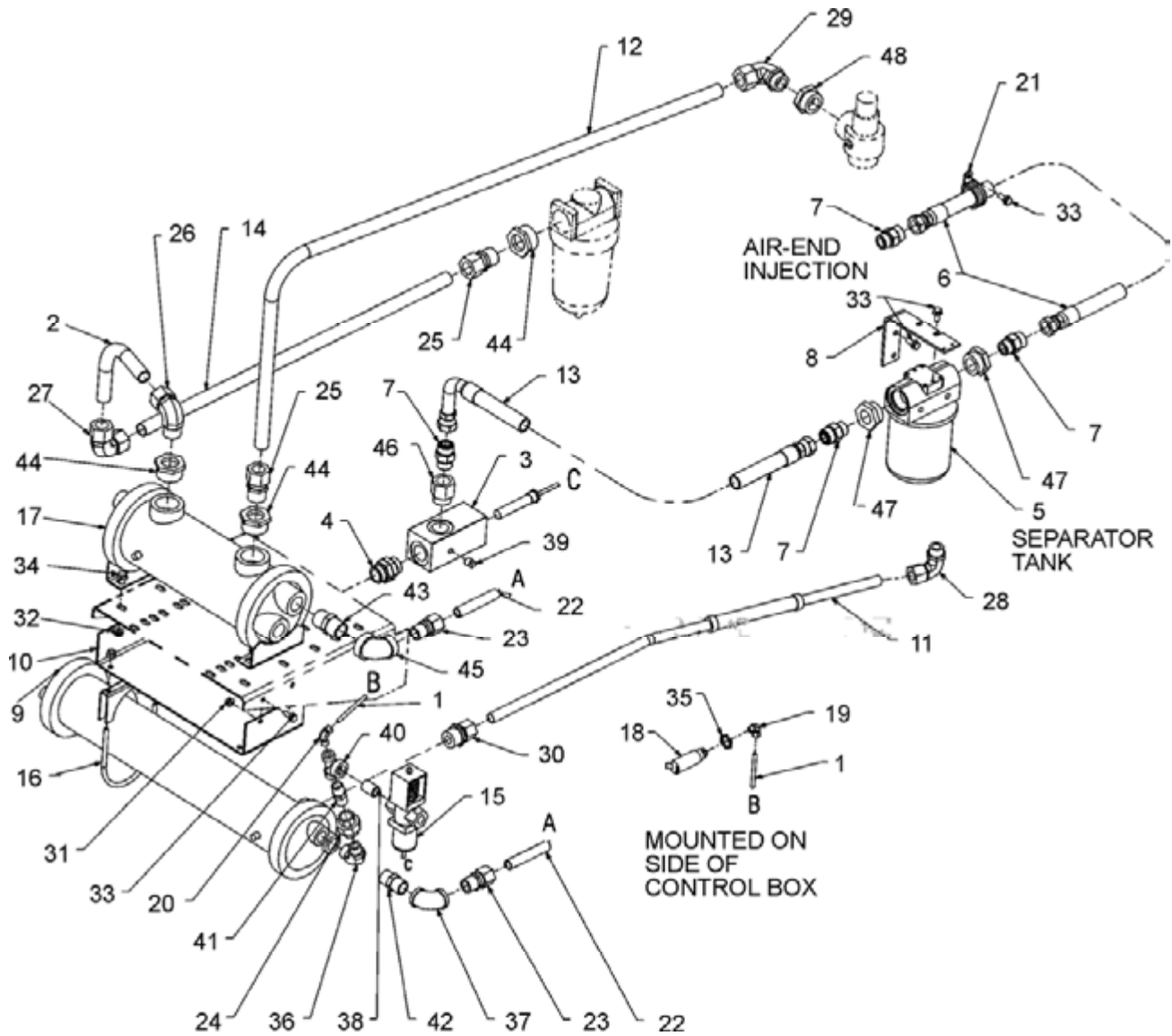
---

**PLEASE NOTE: WHEN ORDERING PARTS, INDICATE SERIAL NUMBER OF COMPRESSOR**

Section 8

# ILLUSTRATIONS AND PARTS LIST

## 8.8 COOLING AND LUBRICATION SYSTEM- WATER-COOLED 40HP/ 30KW



# ILLUSTRATIONS AND PARTS LIST

## 8.8 COOLING AND LUBRICATION SYSTEM- WATER-COOLED 40HP/ 30KW

<i>key number</i>	<i>description</i>	<i>part number</i>	<i>quantity</i>
1	tube,nylon .25"od x .04w black	02250054-861	4 ft
2	tube,1"od ls-10-lf	02250064-798	1
3	tee,sae/npt oil return	02250085-979	1
4	adapter, sae 1 5/16 x 1 5/16-12	02250086-022	1
5	filter, fluid 1 5/8 sae str thrd con <b>(I)</b>	02250096-783	1
6	hose, medium pressure orfs f-swvl end 45"long	02250099-175	1
7	connector,sae x orfs 0.75"	02250099-765	4
8	support, bracket oil filt ls-10 l.f.	02250103-970	1
9	cooler, heat exchanger std sae ports	02250110-238	1
10	support, bracket w.o.clr ls-10-lf	02250110-454	1
11	tube, flexible tank/w.o.c. 3/4"	02250110-456	1
12	tube,1"od aftclr/tank ls-10-40hp w	02250110-458	1
13	hose, medium pressure orfs f-swvl 3/4"x 31" 90	02250113-370	1
14	tube,wc/moist sep ls10	02250113-436	1
15	valve, water regulator 1/2"	041265	1
16	clamp, exhaust 4 1/2"	041983	2
17	heat exchanger, 40hp ls-10-lf air/oi	043062	1
18	switch, pressure n.o. 10 psi	250017-992	1
19	elbow, 90 1/4t pls x 1/8 npt m	250018-429	1
20	elbow, 90 1/4t pls x 1/4 npt m	250018-430	1
21	clamp, tube rubber 1-3/8"F	250025-638	1
22	tubing, nylon 3/4"od	250039-353	3 ft
23	connector,male plastic tubing 3/4" x 3/4	250039-357	2
24	union, pipe galv 1/2	802315-020	1
25	connector, tube-m 1 x 1	810216-100	2
26	elbow, tube 90 deg m 1 x 1	810516-100	1
27	elbow, tube union 1	811216-100	1
28	elbow, tube str thrd 3/4 x 1 1/16	811612-106	1
29	elbow, tube str thrd 1 x 1 5/16	811616-131	1
30	connector, tube str thd 3/4 x 1 5/16	811812-116	1
31	nut,hex f pltd 5/16-18	825305-283	4
32	nut,hex f pltd 3/8-16	825306-347	4
33	screw, hex ser washer 5/16-18 x 3/4	829705-075	9
34	screw, hex ser washer 3/8-16 x 3/4	829706-075	4
35	locknut, conduit 1/2"	847200-050	1

(Continued on page 69)

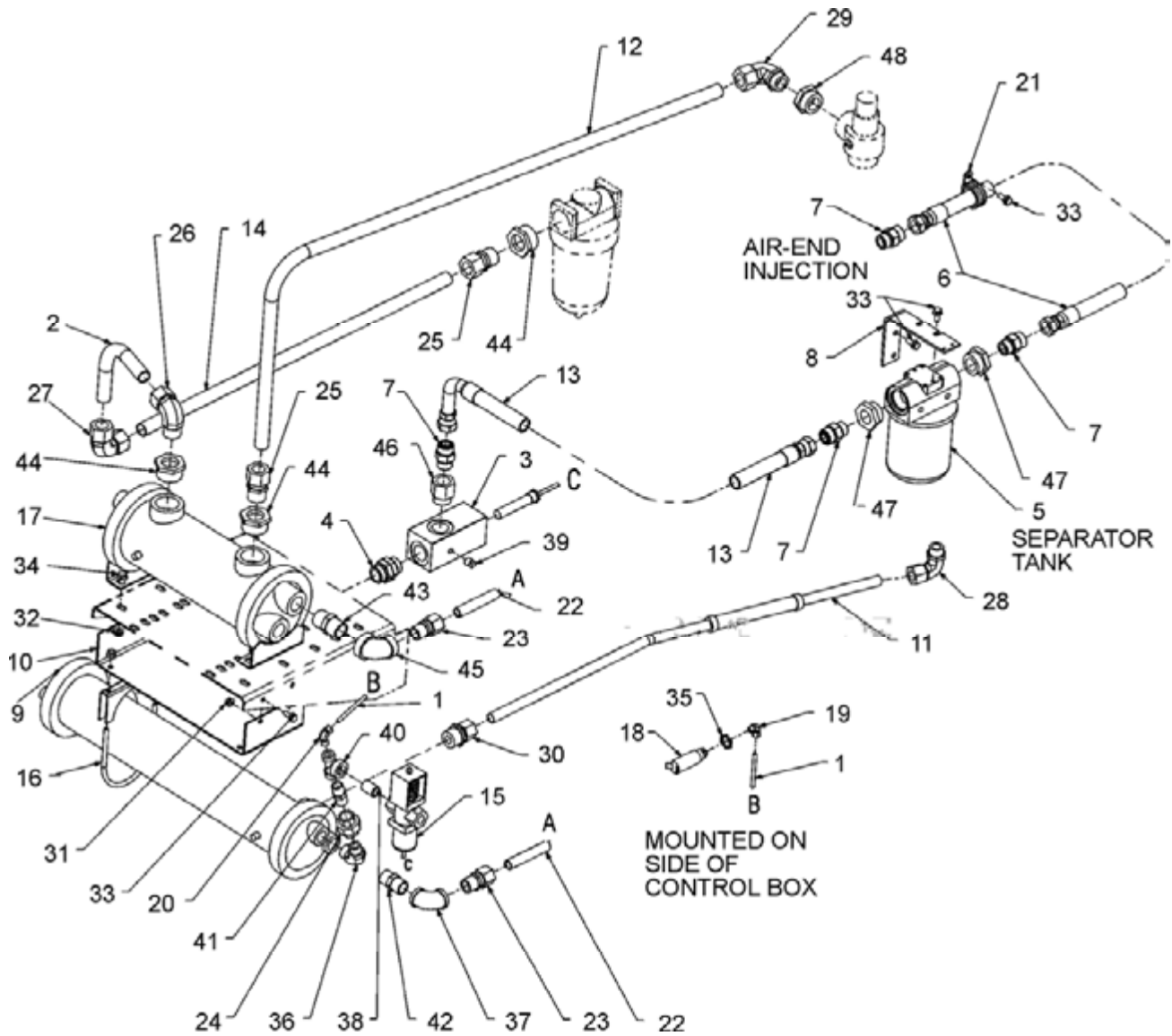
(I) For maintenance on fluid filter no. 02250096-783, order replacement element no. 250025-525.

**PLEASE NOTE: WHEN ORDERING PARTS, INDICATE SERIAL NUMBER OF COMPRESSOR**

Section 8

# ILLUSTRATIONS AND PARTS LIST

## 8.8 COOLING AND LUBRICATION SYSTEM- WATER-COOLED 40HP/ 30KW



# ILLUSTRATIONS AND PARTS LIST

---

## 8.8 COOLING AND LUBRICATION SYSTEM- WATER-COOLED 40HP/ 30KW (CONTINUED)

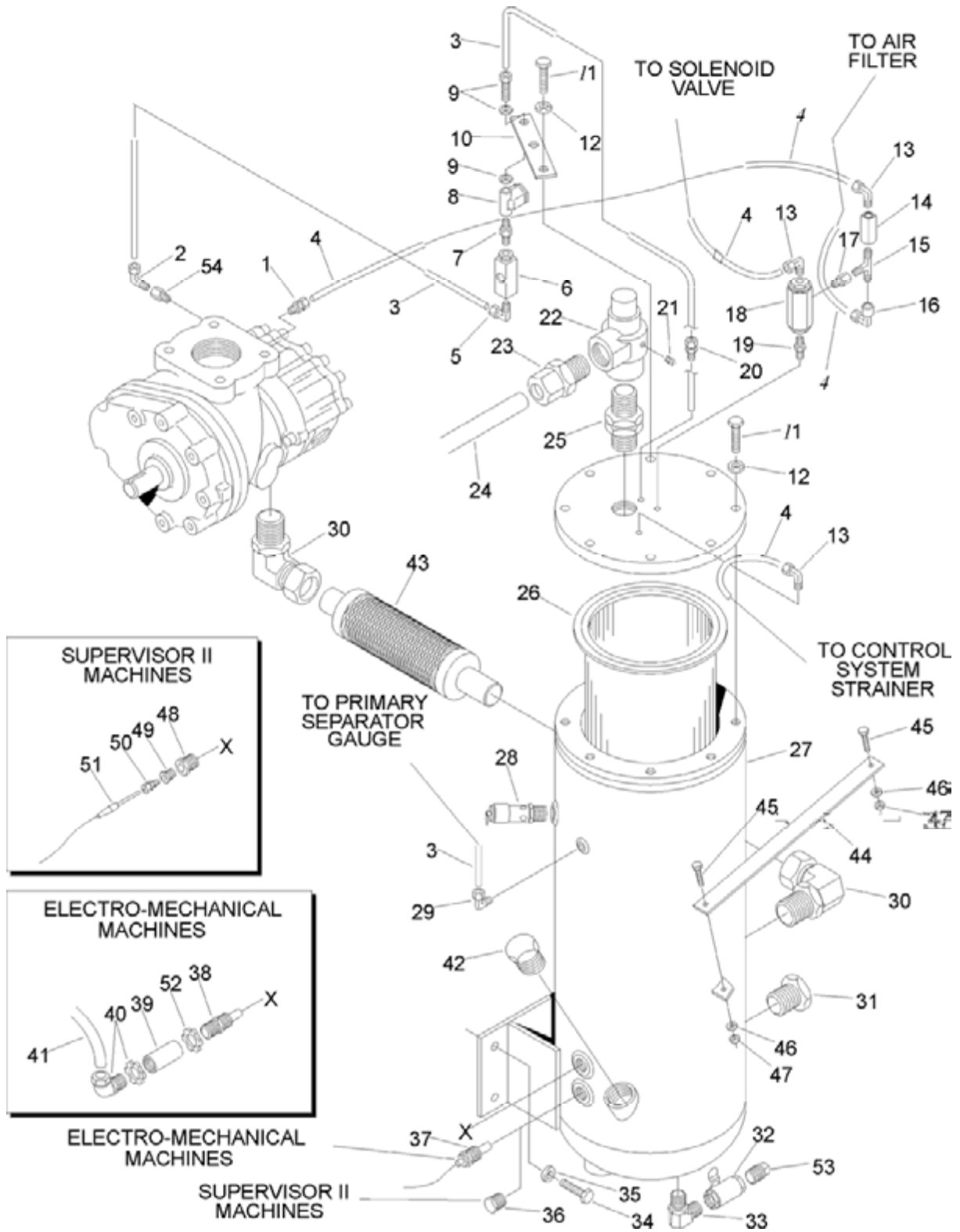
<i>key number</i>	<i>description</i>	<i>part number</i>	<i>quantity</i>
36	elbow, pipe-90m 3/4 x 1/2	860512-050	1
37	elbow, pipe 90 deg plt 3/4"	866215-030	1
38	nipple,pipe-xs plt 1/2 x cl	866408-000	1
39	plug, pipe 1/4" 3000# stl plt	866900-010	1
40	tee, reducing pltd 1/2 x 1/4 x 1/2	867502-012	1
41	nipple,pipe-hx pltd 1/2 x 1/2	868508-050	1
42	nipple,pipe-hx pltd 3/4 x 3/4	868512-075	1
43	nipple,pipe-hx pltd 1 x 1	868516-100	1
44	bushing,red hex pltd 1 1/2 x 1	868906-040	3
45	elbow, red 1 x 3/4 150# plt	869204-030	1
46	reducer,str thrd viton 1 x 3/4	870016-012	1
47	reducer,str thrd viton 1 1/4 x 3/4	870020-012	2
48	reducer,str thrd viton 1 1/4 x 1	870020-016	1

---

**PLEASE NOTE: WHEN ORDERING PARTS, INDICATE SERIAL NUMBER OF COMPRESSOR**

# ILLUSTRATIONS AND PARTS LIST

## 8.9 DISCHARGE SYSTEM



# ILLUSTRATIONS AND PARTS LIST

## 8.9 DISCHARGE SYSTEM

<i>key number</i>	<i>description</i>	<i>part number</i>	<i>quantity</i>
1	connector, 1/4"tube x 1/4"npt	250018-428	1
2	elbow, tube-m 1/4"t x 1/8"p stainless steel	250211-013	1
3	tube, stainless steel 1/4" 20ga	841215-004	-
4	tube, nylon 1/4" black	02250054-861	-
5	elbow, tube-m 1/4" stainless steel	250211-005	1
6	glass, sight-in line 1/4"npt	046559	1
7	orifice, .094" 1/4"npt steel	022033	1
8	strainer, v-type 300psi x 1/4"npt (I)	241771	1
9	connector, tube-male bulkhead 1/4"t x 1/4"p ststl	870204-025	1
10	support, bracket-oil return	02250101-192	1
11	capscrew, hex gr5 1/2"-13 x 1-1/4" plated	829108-125	8
12	washer, springlock reg plated 1/2"	837808-125	8
13	elbow, 1/4"tube x 1/4"npt	250018-430	3
14	valve, check 1/4" nptf brass viton seal	02250115-272	1
15	tee, pipe 1/4" male npt	869825-025	1
16	elbow, female 1/4"npt x 1/4"T	250041-287	1
17	orifice, .125" x 1/4"mnpt x 1/4"fnpt	02250046-537	1
18	valve, blowdown 1/4" npt	02250049-634	1
19	nipple, pipe 1/4"npt hex	868504-025	1
20	connector, flex 1/4"t x 1/4"p	020169	1
21	plug, pipe 1/8"npt 3000# plated	866900-005	1
22	valve, minimum pressure check 1-5/8" SAE (II)	02250097-609	1
23	connector, tube-straight thread 1" x 1-5/8"	811816-163	1
24	tube, minimum pressure valve/aftercooler	02250099-372	1
25	adapter, SAE 1-5/8"-12 x 1-5/8"-12	02250055-015	1
26	element, separator-primary (III)	250034-113	1
27	tank, separator air/oil 10"dia SAE/ISO	02250096-708	1
28	valve, pressure relief 1/2"npt 200#	250006-938	1
29	elbow, tube-m straight thread ss 1/4" x 7/16"	870807-025	1
30	elbow, tube straight thread 1-1/2" x 1-7/8"	811624-188	2

(Continued on page 73)

(I) For maintenance on strainer no. 241771, order repair kit no. 241772.

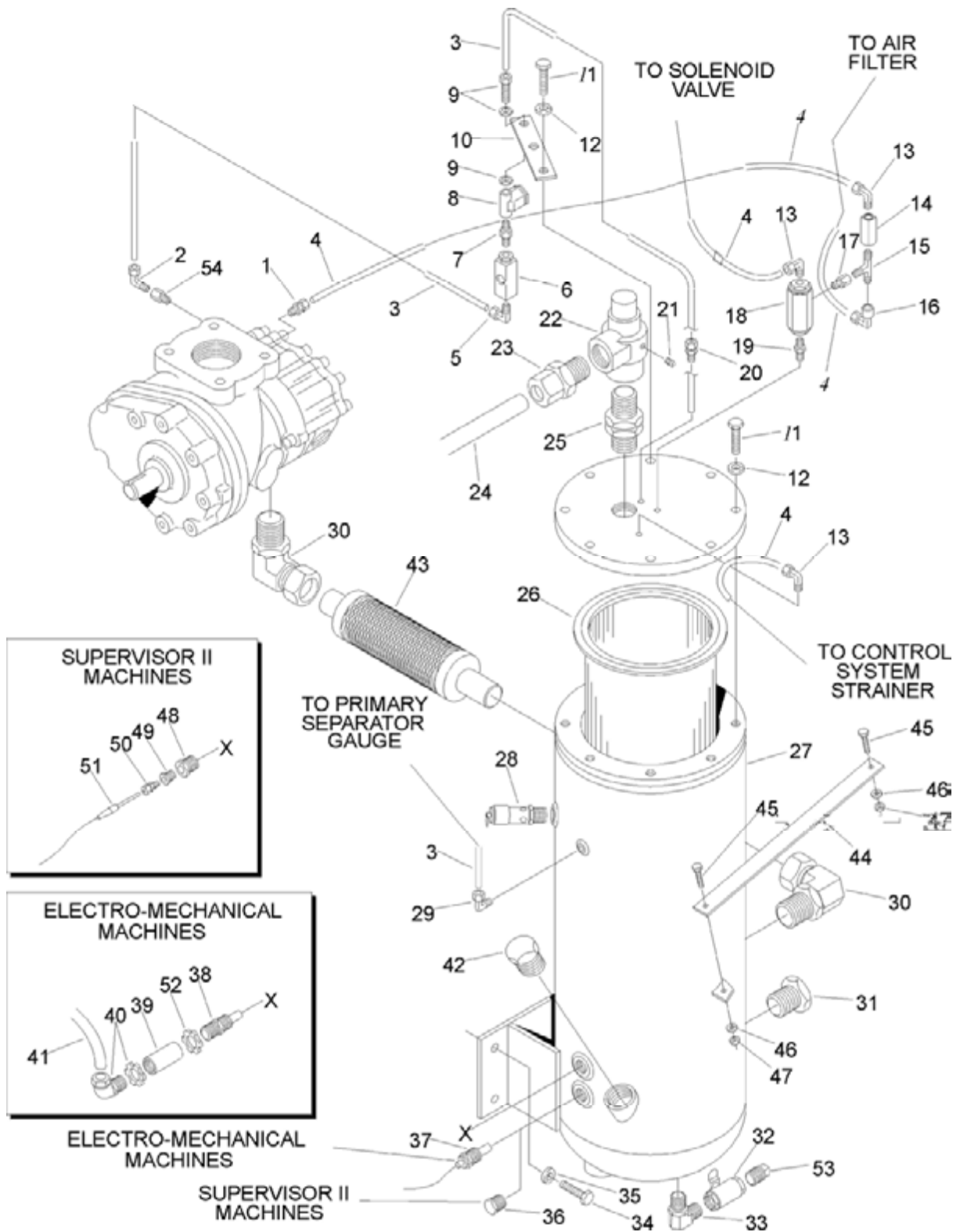
(II) For maintenance on minimum pressure check valve no. 02250097-609, order repair kit no. 250026-758; repair kit (for cap) no. 02250046-397; repair kit (for o-ring) no. 02250048-362; repair kit (for piston) no. 02250051-338.

(III) For maintenance on separator element, order replacement element no. 250034-114.

**PLEASE NOTE: WHEN ORDERING PARTS, INDICATE SERIAL NUMBER OF COMPRESSOR**

# ILLUSTRATIONS AND PARTS LIST

## 8.9 DISCHARGE SYSTEM



# ILLUSTRATIONS AND PARTS LIST

## 8.9 DISCHARGE SYSTEM (CONTINUED)

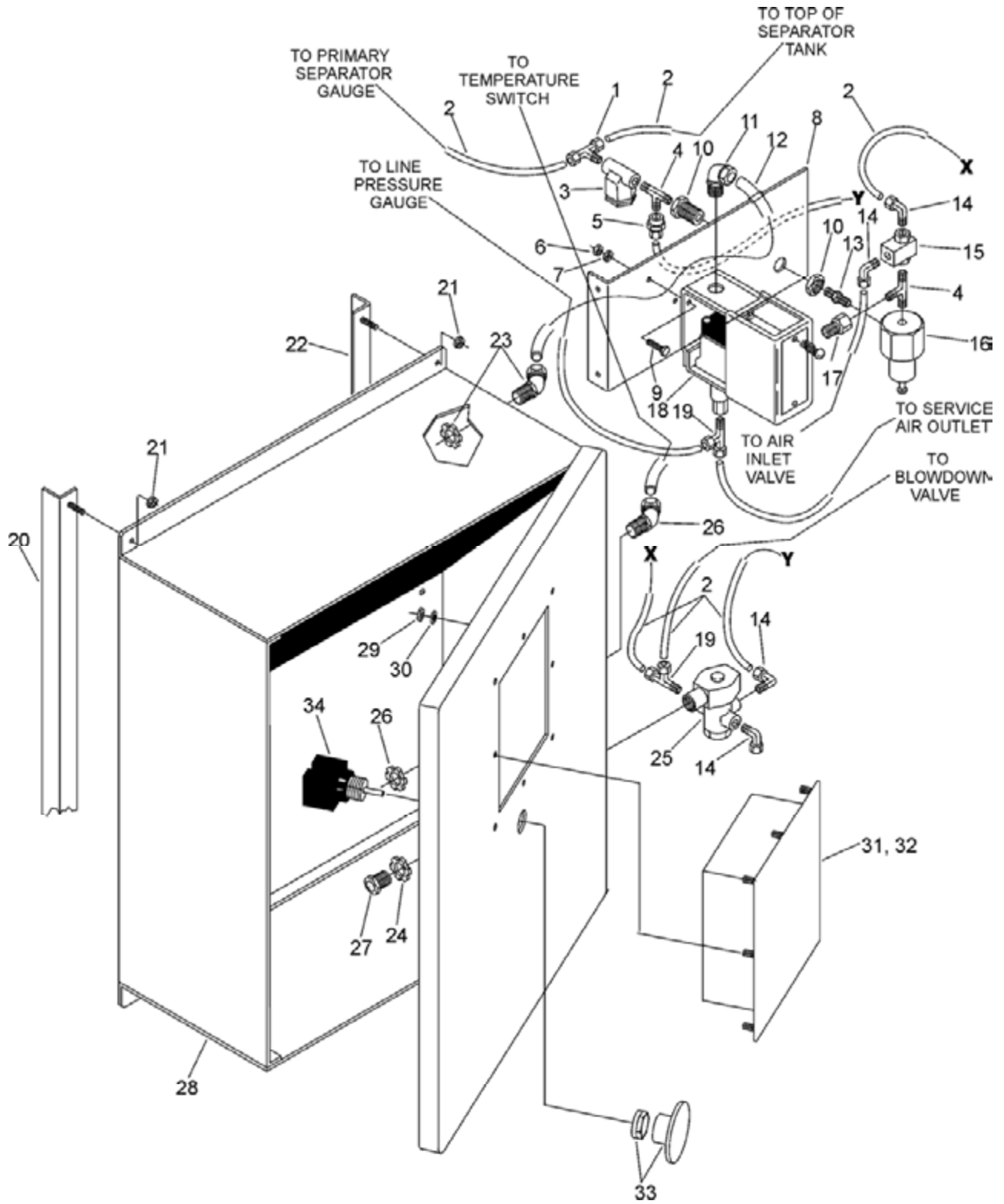
<i>key number</i>	<i>description</i>	<i>part number</i>	<i>quantity</i>
31	plug, sight glass 1-5/16"SAE	02250097-610	1
32	valve, ball 3/8"m x 3/8"f nptf	02250100-094	1
33	elbow, 90_ 3/4"SAE x 3/8"f nptf	02250100-093	1
34	capscrew, hex gr5 1/2"-13 x 1-1/4" plated	829108-125	4
35	washer, springlock reg plated 1/2"	837808-125	4
36	plug, straight thread 3/4"-16 SAE viton	250042-623	1
37	gauge, temperature-ump 100_-250_	02250100-096	1
38	switch, temperature 240_ 3/4" SAE	02250100-095	1
39	coupling, conduit 1/2"	250007-179	1
40	elbow, 90_ conduit 1/2"	846600-050	1
41	conduit, csa flex 1/2"	846315-050	2.5 ft
42	plug, o-ring 1-1/4"	040029	1
43	joint, expansion ls10 unit/tank	02250097-823	1
44	support, tank brace ls10	02250107-906	1
45	capscrew, hex gr5 3/8"-16 x 1"	829106-100	2
46	washer, springlock reg plated 3/8"	837806-094	2
47	nut, hex plated 3/8"-16	825206-337	2
48	adapter, pipe-f 1/2"SAE x 1/4"npt	811504-025	1
49	bushing, reducing 1/4" x 1/8" plated	867100-005	1
50	fitting, compression adjustable	250028-635'	1
51	probe, rtd 100 ohm platinum	250039-909	1
52	locknut, conduit 1/2"	847200-050	1
53	plug, pipe 3/8" 3000# steel	807800-015	1
54	orifice, 1/8 m x 1/8 f x .062	224427	1
55	decal, fluid Sullube	02250069-389	1
	Sdecal, fluid 24KT	02250069-395	1
	Sdecal, fluid SRF 1/4000	02250069-391	1
56	decal, warning mixing fluids	02250110-891	1
57	sign, warning compressor fluid fill cap	049685	1

**PLEASE NOTE: WHEN ORDERING PARTS, INDICATE SERIAL NUMBER OF COMPRESSOR**

Section 8

# ILLUSTRATIONS AND PARTS LIST

## 8.10 CONTROL SYSTEM AND ELECTRICAL PARTS



# ILLUSTRATIONS AND PARTS LIST

## 8.10 CONTROL SYSTEM AND ELECTRICAL PARTS

<i>key number</i>	<i>description</i>	<i>part number</i>	<i>quantity</i>
1	tee, tube 1/4" male branch	250028-582	1
2	tubing, nylon 1/4" black	0225054-861	-
3	strainer, v-type 300 psi x 1/4" npt <b>(I)</b>	241771	1
4	tee, pipe 1/4" male npt	869825-025	2
5	connector, 1/4" tube x 1/4" female npt	250041-084	1
6	nut, hex plated #10-24	825202-130	2
7	washer, springlock reg plated #10	837802-047	2
8	support, bracket pneumatic cntrls	02250104-420	1
9	screw, machine-round #10-24 x 1/2"	831602-050	2
10	bulkhead, pipe 1/4" npt	841500-025	1
11	elbow, 90_ conduit 1/4	846600-050	1
12	conduit, csa flex 1/2"	846315-050	0.4 ft
13	nipple, ipe 1/4" hex	868504-025	1
14	elbow, 1/4" tube x 1/4" npt	250018-430	4
15	valve, shuttle 1/4" npt	408893	1
16	valve, pressure regulator <b>(II)</b>	250017-280	1
17	orifice, .040 x 1/4" fnpt x 1/4" mnpt	02250091-395	1
18	switch, pressure (<= 140 psi/ 9.7 bar) (N12)	040694	1
	Sswitch, pressure (<= 140 psi/ 9.7 bar) (N4)	042570	1
	Sswitch, pressure (< 140 psi/ 9.7 bar) (N12)	407778	1
	Sswitch, pressure (< 140 psi/ 9.7 bar) (N4)	410108	1
19	tee, tube 1/4" male run	250038-059	2
20	support, bracket strtr box ls 10 lh	02250106-969	1
21	nut, hex flanged plated 5/16"-18	825305-283	4
22	support, bracket strtr box ls 10 rh	02250104-194	1
23	elbow, 45_ conduit 1/2"	846500-050	1
24	locknut, conduit seal N4 1/2"	02250071-362	1
25	valve, solenoid 1/4" 3-way (<= 140 psi/ 9.7 bar) <b>(III)</b>	250038-674	1
	Svalve, solenoid 1/4" 3- way (> 140 psi/ 9.7 bar) <b>(IV)</b>	250038-675	1
26	elbow, 45_conduit1/2"	846500-050	1

(Continued on page 77)

**(I)** For maintenance on strainer no. 241771, order repair kit no. 241772.**(II)** For maintenance on pressure regulator valve no. 250017-280, order repair kit no. 250019-453.**(III)** For maintenance on solenoid valve no. 250038-674, order repair kit no. 250038-673, and replacement coil no. 250031-772.**(IV)** For maintenance on solenoid valve no. 250038-675, order repair kit no. 02250055-939, and replacement coil no. 250038-730.

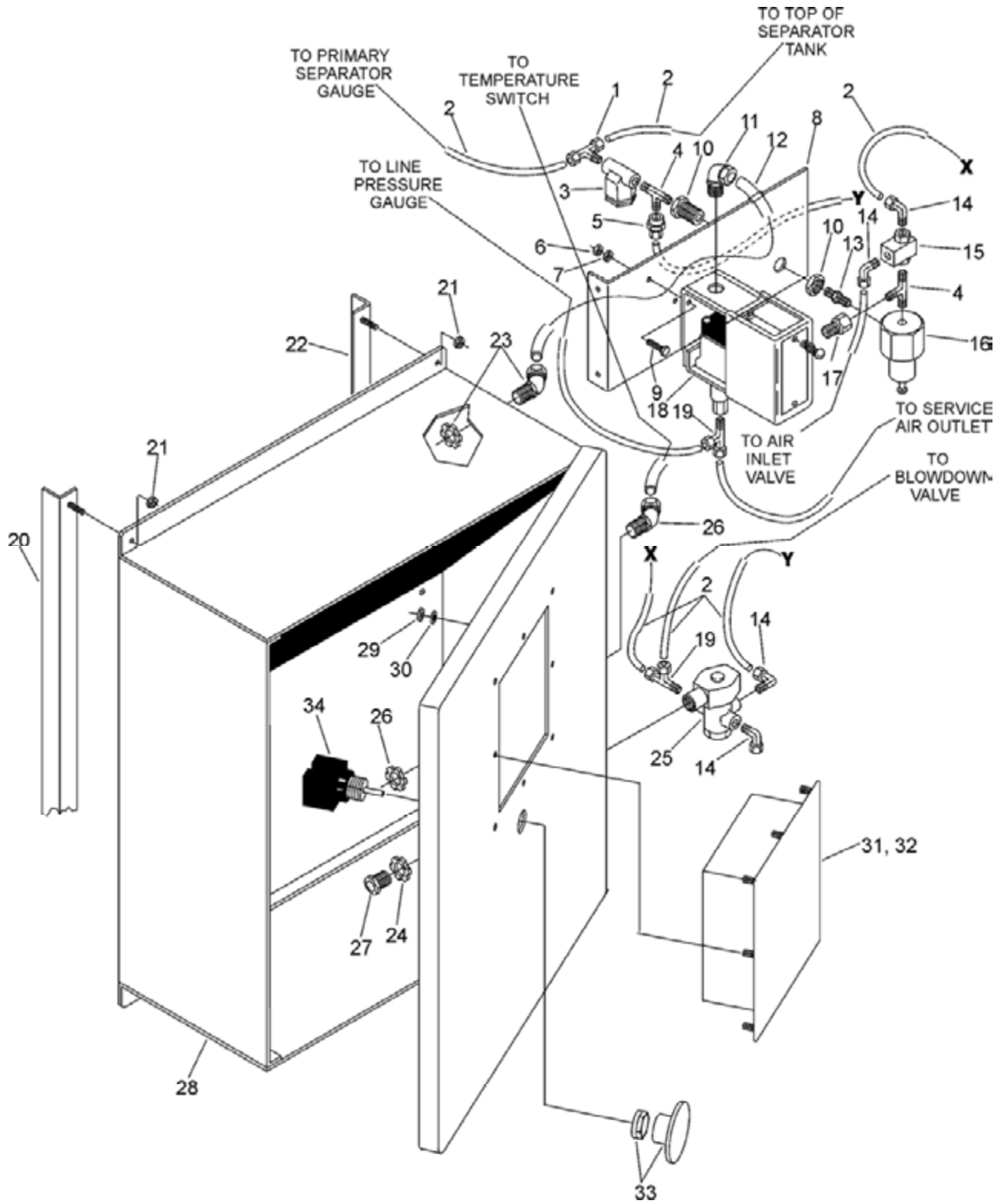
---

**PLEASE NOTE: WHEN ORDERING PARTS, INDICATE SERIAL NUMBER OF COMPRESSOR**

Section 8

# ILLUSTRATIONS AND PARTS LIST

## 8.10 CONTROL SYSTEM AND ELECTRICAL PARTS



# ILLUSTRATIONS AND PARTS LIST

---

## 8.10 CONTROL SYSTEM AND ELECTRICAL PARTS (CONTINUED)

<i>key number</i>	<i>description</i>	<i>part number</i>	<i>quantity</i>
27	nipple, chase 1/2"	847815-050	1
28	box, electrical strtr ls 10	consult factory	1
30	washer, springlock m4	838804-090	8
31	gasket, panel Supervisor II	02250048-822	1
32	controller, electro-mechanical	02250106-694	1
	Scontroller, Supervisor II dlx	02250083-801	1
33	switch, emergency shut-off	02250085-504	1

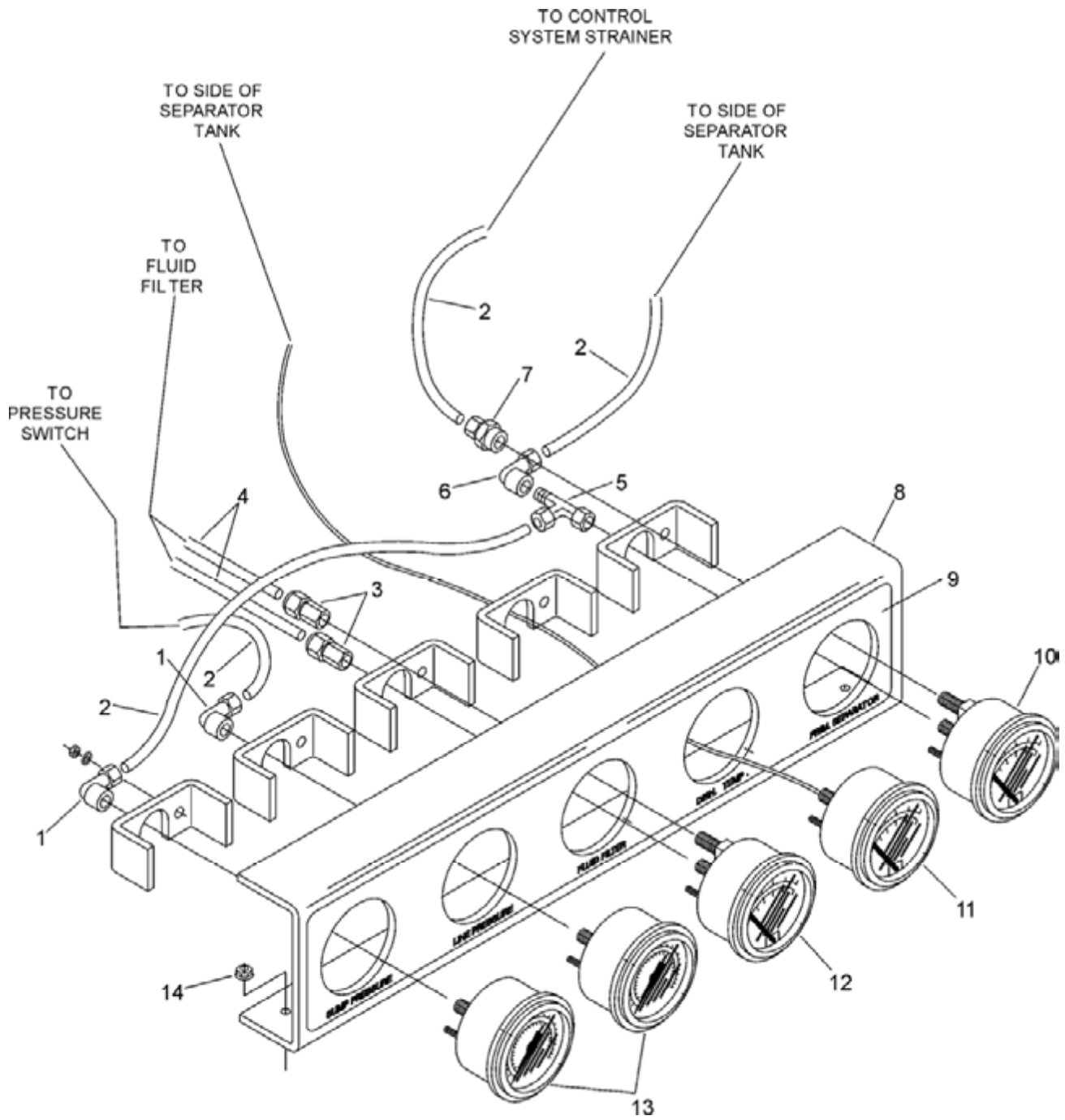
---

**PLEASE NOTE: WHEN ORDERING PARTS, INDICATE SERIAL NUMBER OF COMPRESSOR**

# Section 8

## ILLUSTRATIONS AND PARTS LIST

### 8.11 INSTRUMENT PANEL



# ILLUSTRATIONS AND PARTS LIST

---

## 8.11 INSTRUMENT PANEL

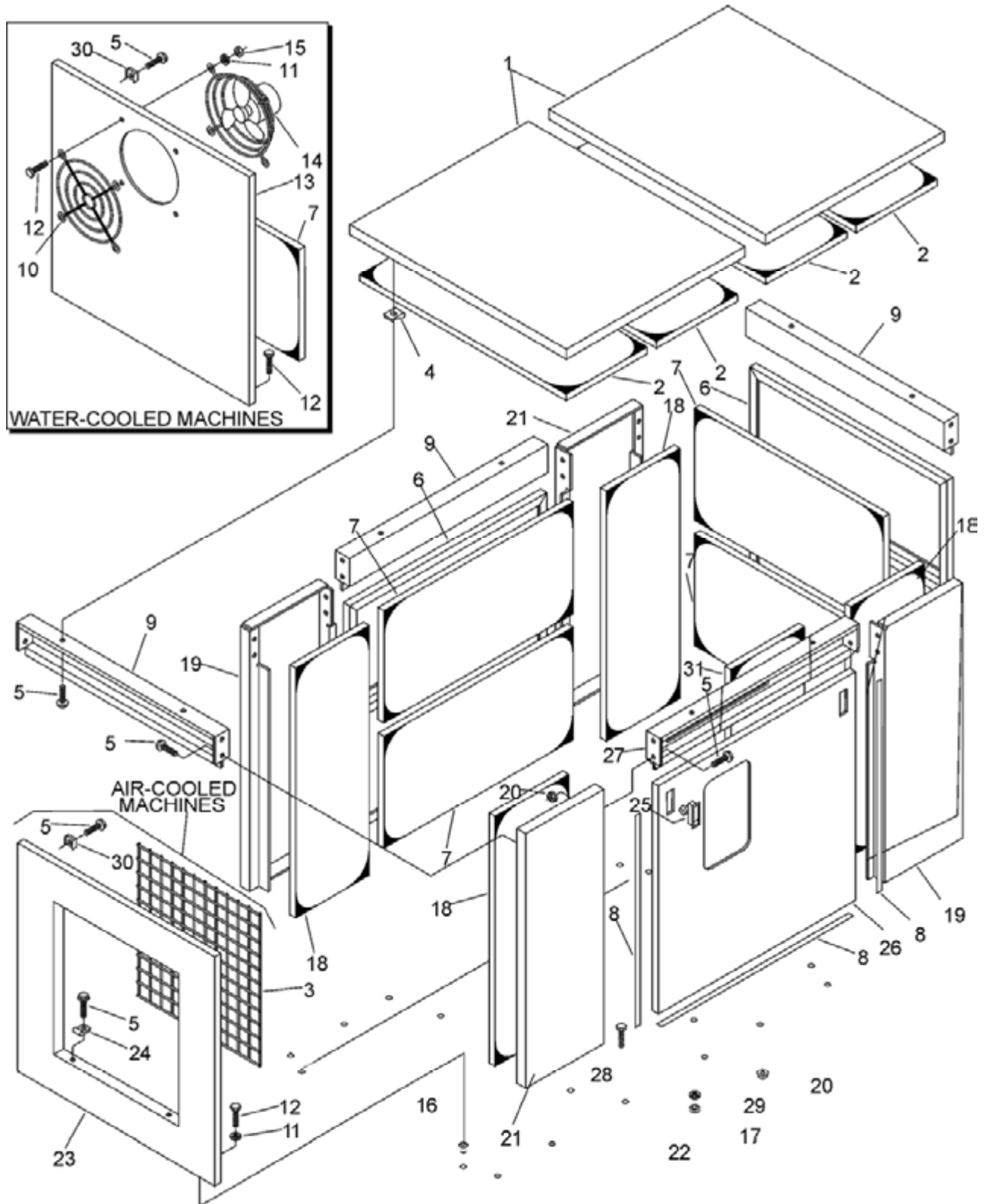
<i>key number</i>	<i>description</i>	<i>part number</i>	<i>quantity</i>
1	elbow, 90_ 1/4"t x 1/8" female npt	250041-286	2
2	tubing, nylon 1/4" black	02250054-861	-
3	connector, tube-f 1/4"t x 1/8"p stainless steel	250139-050	2
4	tubing, stainless steel 1/4" 20ga	841215-004	-
5	tee, adaptor 1/4"t x 1/8"m x 1/8"f	869704-012	1
6	elbow, tube-f 1/4"t x 1/8"p stainless steel	250211-030	1
7	connector, female 1/4"t x 1/8"npt	250021-379	1
8	panel, mounting gauge e/mdc	02250104-355	1
9	decal, instrument panel 10 series universal	02250060-034	1
10	gauge, differential pressure 0-30psi	250003-799	1
11	gauge, temperature 100_-250_F-3/4" SAE	02250100-096	1
12	gauge, differential pressure 0-15psi	250003-798	1
13	gauge, pressure 2" dia 0-230#	250005-185	2
14	nut, hex flanged plated 5/16"-18	825305-283	2

---

**PLEASE NOTE: WHEN ORDERING PARTS, INDICATE SERIAL NUMBER OF COMPRESSOR**

# Section 8 ILLUSTRATIONS AND PARTS LIST

## 8.12 ENCLOSURE



# ILLUSTRATIONS AND PARTS LIST

## 8.12 ENCLOSURE

<i>key number</i>	<i>description</i>	<i>part number</i>	<i>quantity</i>
1	panel, roof ls10	250018-316	2
2	panel, fiberglass 5" x 35-1/2"		4
3	connector, tube-f 1/4"t x 1/8"p stainless steel	242095	1
4	nut, retainer "j" 5/16"-18	861505-140	14
5	screw, ser washer 5/16" x 3/4"(AC)	829705-075	40
	Sscrew, ser washer 5/16" x 3/4"(WC)	829705-075	36
6	panel, access	014620	2
7	panel, fiberglass 15-1/4" x 32-1/2"		4
8	weatherstrip, felt	02250058-345	75
9	panel, enclosure center	224585	3
10	guard, fan 13"	241579	1
11	washer, springlock reg plated 1/4"(AC)	837804-062	8
	Swasher, springlock reg plated 1/4"(WC)	837804-062	12
12	capscrew, hex gr5 1/4"-20 x 1"(AC)	829104-100	8
	Scapscrew, hex gr5 1/4"-20 x 1"(WC)	829104-100	12
13	panel, wc end	02250043-677	1
14	fan, enclosure wc	241580	1
15	nut, hex plated 1/4"-20	825204-226	4
16	rivet, tubular 1/4"-20	049824	8
17	nut, hex plated 1/2"-13	825208-448	4
18	panel, fiberglass 13" x 36-1/2"	250020-059	4
19	panel, enclosure - right hand corner	224583	2
20	nut, hex ser washer 5/16"-18 plated (AC)	825305-283	28
	Snut, hex ser washer 5/16"-18 plated (WC)	825305-283	24
21	panel, enclosure-left hand corner	224584	2
22	frame, enclosure-sub	014790	1
23	panel, cooler end (AC)	02250105-122	1
24	clamp, wire	043194	4
25	latch, door black	02250094-632	4
26	panel, access front	02250105-123	1
27	panel, enclosure instrument access(e/m dc)	02250104-191	1
	Spanel, enclosure center(supervisor)	224585	1
28	capscrew, hex gr5 pltd 1/2"-13 x 1-1/2"	829108-150	4
29	washer, springlock reg plated 1/2"	837808-125	4
30	nut, retainer 5/16"-18	861405-092	4
31	panel, fiberglass	250034-038	1

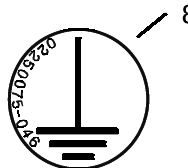
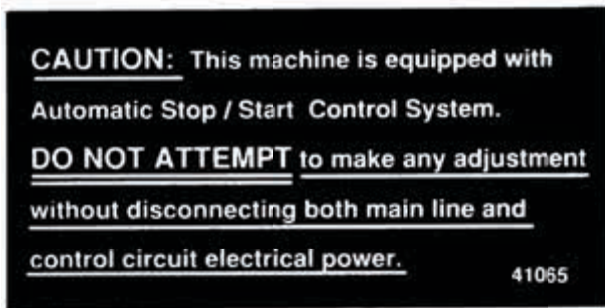
**PLEASE NOTE: WHEN ORDERING PARTS, INDICATE SERIAL NUMBER OF COMPRESSOR**

Section 8  
**ILLUSTRATIONS AND PARTS LIST**

8.13 DECAL GROUP



250038-457	1 CR	1 TR	LINE PRESS	INLET
	2 CR	2 TR	DISCH PRESS	T1
	3 CR	3 TR	WATER PRESS	T2
	4 CR	4 TR	SEPARATOR	T3
	5 CR	1 M	SPIRAL VALVE	T4
	6 CR	2 M	INLET VALVE	T5
	1 FU	3 M	CIS VALVE	T6
	2 FU	4 M	OIL PRESS	T3
	3 FU	HCR	OIL FILTER	T4



# ILLUSTRATIONS AND PARTS LIST

---

## 8.13 DECAL GROUP

<i>key number</i>	<i>description</i>	<i>part number</i>	<i>quantity</i>
1	decal, fork lifting	241814	4
2	decal, electrical component	250038-457	1
3	sign, warning sever fan	049855	2
4	sign, warning sever fan port	049965	1
5	sign, danger electrocution	049850	1
6	decal, warning auto start	041065	1
7	decal, 460 voltage international <b>(I)</b>	02250069-399	1
8	decal, earth ground	02250075-046	1
	Sdecal, protective earth ground (not shown)	02250075-045	1
	Sdecal, PE designation (not shown)	02250075-540	1
9	decal, warning ground fault	049852	1
10	decal, water drain	250022-810	1
11	decal, LS-10 2" high	02250060-916	1

(Continued on page 85)

**(I)** Compressor voltage may vary. Consult Factory with machine serial number.

---

**PLEASE NOTE: WHEN ORDERING PARTS, INDICATE SERIAL NUMBER OF COMPRESSOR**

Section 8  
**ILLUSTRATIONS AND PARTS LIST**

8.13 DECAL GROUP

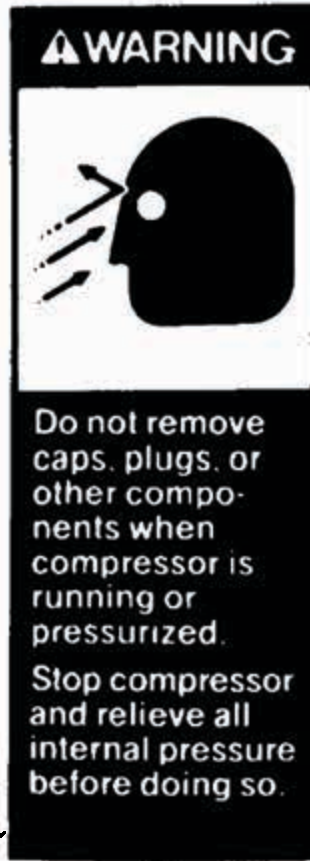


12

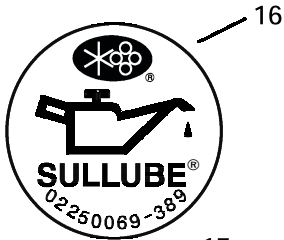
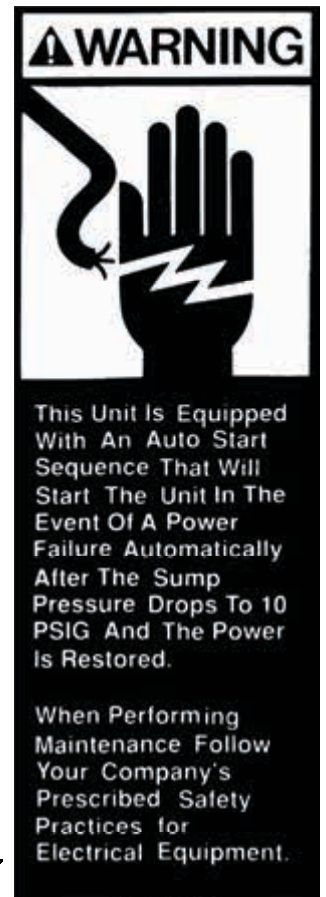


13

14

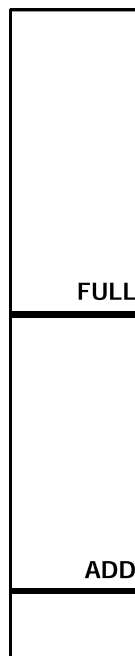


15



17

18



19



20



21



22



# ILLUSTRATIONS AND PARTS LIST

---

## 8.13 DECAL GROUP (CONTINUED)

<i>key number</i>	<i>description</i>	<i>part number</i>	<i>quantity</i>
12	sign, warning "food grade" lube	250003-144	1
13	sign, danger air breathing	250027-935	1
14	sign, warning compressor fluid fill cap	049685	1
15	decal, warning auto start	250017-903	1
16	decal, fluid Sullube	02250069-389	1
	Sdecal, fluid 24KT (not shown)	02250069-395	1
	Sdecal, fluid SRF 1/4000 (not shown)	02250069-391	1
17	decal, warning mixing fluids	02250110-891	1
18	decal, gauge fluid level	250020-730	1
19	decal, danger high voltage	042218	1
20	decal, "water in"	250019-107	1
21	decal, "water out"	250019-108	1
22	decal, water inlet/outlet	049873	1

(Continued on page 87)

---

**PLEASE NOTE: WHEN ORDERING PARTS, INDICATE SERIAL NUMBER OF COMPRESSOR**

# Section 8 ILLUSTRATIONS AND PARTS LIST

## 8.13 DECAL GROUP



23

24

25

26

# 24KT

This product was manufactured to the highest quality standards in an ISO 9001 certified system.  
Ce produit a été fabriqué selon les normes les plus strictes de qualité dans un système ISO 9001 certifié.  
Dieses Produkt wurde in einem mit ISO 9001 Zertifikat versehenen System hergestellt und entspricht den höchsten Qualitätsnormen.  
Dette produkt er fremstillet i overensstemmelse med de strengeste kvalitetsnormer i et ISO 9001 - certificeret anlæg.

# ISO 9001

Το προϊόν αυτό έχει κατασκευαστεί σύμφωνα με τις πλέον αυστηρές προδιαγραφές ποιότητας σε εγκατάσταση πιστοποιημένη με ISO 9001.  
Dit produkt werd volgens de hoogste kwaliteitseisen geproduceerd in een ISO 9001 gecertificeerd kwaliteitssysteem.  
Este producto ha sido fabricado según los más altos estándares de calidad en un sistema con la certificación ISO 9001.  
Questo prodotto è stato fabbricato secondo i più alti standard qualitativi, in un sistema omologato ISO 9001.  
本產品是由取得最高品質水準 ISO 9001 資格之製造廠所生產

© Copyright 1998 Sullair Corporation. All Rights Reserved

### GENUINE SULLAIR SERVICE PARTS

MODEL:  
LS10 25HP, 30HP & 40HP

DESCRIPTION:	P/N
ELEMENT, SEPARATOR	250034-114
ELEMENT, AIR FILTER (25/30HP)	043334
ELEMENT, AIR FILTER (40HP)	040596
ELEMENT, FLUID FILTER	250025-525
KIT, THERMO VLV REPAIR (170°F)	250025-621
KIT, THERMO VLV REPAIR (190°F)	02250103-562
KIT, INLET VALVE REPAIR	250019-451
KIT, INLET VALVE SPRING	250029-315
KIT, MIN PRESS CHECK REPAIR	02250110-988
KIT, BLOWDOWN VALVE REPAIR	250031-772
KIT, FLUID RETURN LINE STRAINER	241772
KIT, PRESSURE REGULATOR REPAIR	250019-453

**\*\* STD. COMPRESSOR FLUID OPTIONS:**

SRF 1/4000 FLUID (5 GAL.)	250019-662
SULLUBE 32 FLUID (5 GAL.)	250022-869
24KT FLUID (5 GAL.)	022500051-053

**\*\* SEE COMPR. FILL DECAL FOR CORRECT FLUID**

THE ABOVE PARTS SHOULD BE ORDERED FROM A LOCAL SULLAIR DISTRIBUTOR. FOR INFORMATION REGARDING THE LOCATION OF YOUR NEAREST SULLAIR DISTRIBUTOR CONTACT:

SULLAIR CORPORATION TEL. (800) SULLAIR  
PARTS DIVISION  
1625 E. SECOND ST.  
MICHIGAN CITY, IN. 46360

02250103-910

**DANGER!**  
Lethal shock hazard. Disconnect all power at source before opening or servicing.


**DANGER!**  
Danger mortel d'électrocution. Débranchez toute source d'alimentation avant toute ouverture ou intervention de maintenance de la machine.

**GEFAHR!**  
Tödlich Stromschlaggefahr. Vor jeder Öffnung oder jedem Eingriff am Anlasserrelais oder am Schaltschrank sämtliche Stromzufuhren ziehen.

**PERICOLO!**  
Pericolo mortale di elettrocuzione. Disinserire tutte le fonti di alimentazione prima di qualsiasi apertura o di qualsiasi intervento di manutenzione della macchina.

**¡PELIGRO!**  
Peligro mortal de electrocución. Desconectar todas las fuentes de alimentación antes de abrir o de realizar una intervención de mantenimiento en la máquina.

**！危険**  
内有高压，小心触电。拆卸保养之前应断开所有电源。



27

28

MACH. S-N \_\_\_\_\_ MODEL # \_\_\_\_\_

CUST. NAME \_\_\_\_\_

ADDRESS \_\_\_\_\_

CITY / STATE \_\_\_\_\_ ZIP \_\_\_\_\_

CUST. PRODUCT \_\_\_\_\_

BRAND OF FLUID \_\_\_\_\_

HOURS ON MACH. \_\_\_\_\_ FLUID \_\_\_\_\_

DATE SAMPLE TAKEN: \_\_\_\_\_

DISCHARGE TEMP. \_\_\_\_\_ °F

AMBIENT TEMP. \_\_\_\_\_ °F

FLUID USAGE RATE - GAL / MO. \_\_\_\_\_

SAMPLE TAKEN FROM: \_\_\_\_\_

COMMENTS: \_\_\_\_\_

\_\_\_\_\_

\_\_\_\_\_

# ILLUSTRATIONS AND PARTS LIST

---

## 8.13 DECAL GROUP (CONTINUED)

<i>key number</i>	<i>description</i>	<i>part number</i>	<i>quantity</i>
23	decal, Sullair	02250059-054	2
24	decal, 24 KT	02250061-016	1
25	decal, maintenance kit LS-10	02250103-910	1
26	decal, ISO 9001	02250057-624	1
27	decal, electrocution hazard international	02250077-472	1
28	decal, fluid sample	250022-675	1
32	plate, rotation arrow (not shown)	02250057-737	1
33	decal, instrument pnl universal (not shown)	02250051-301	1
34	decal, instument pnl universal (not shown)	02250051-303	1
35	decal, instrument pnl universal-dual cntrl (not shown)	02250059-410	1
36	decal, instrument pnl 10 Series universal (see Section 8.9)	02250060-034	1
37	label, Supervisor II info univ dlx (not shown)	02250071-152	1

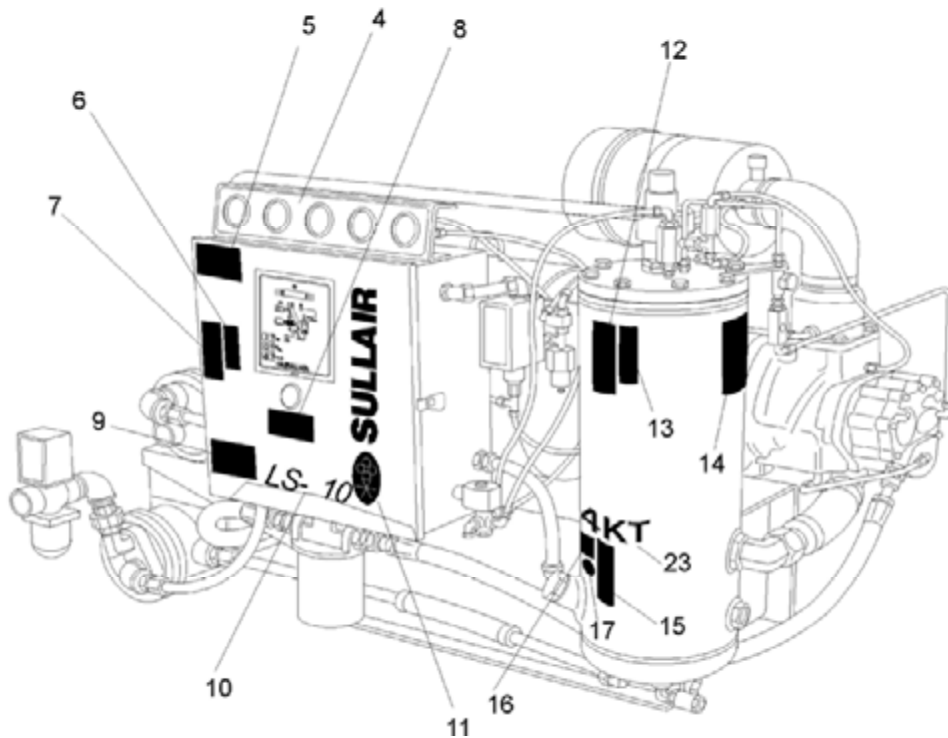
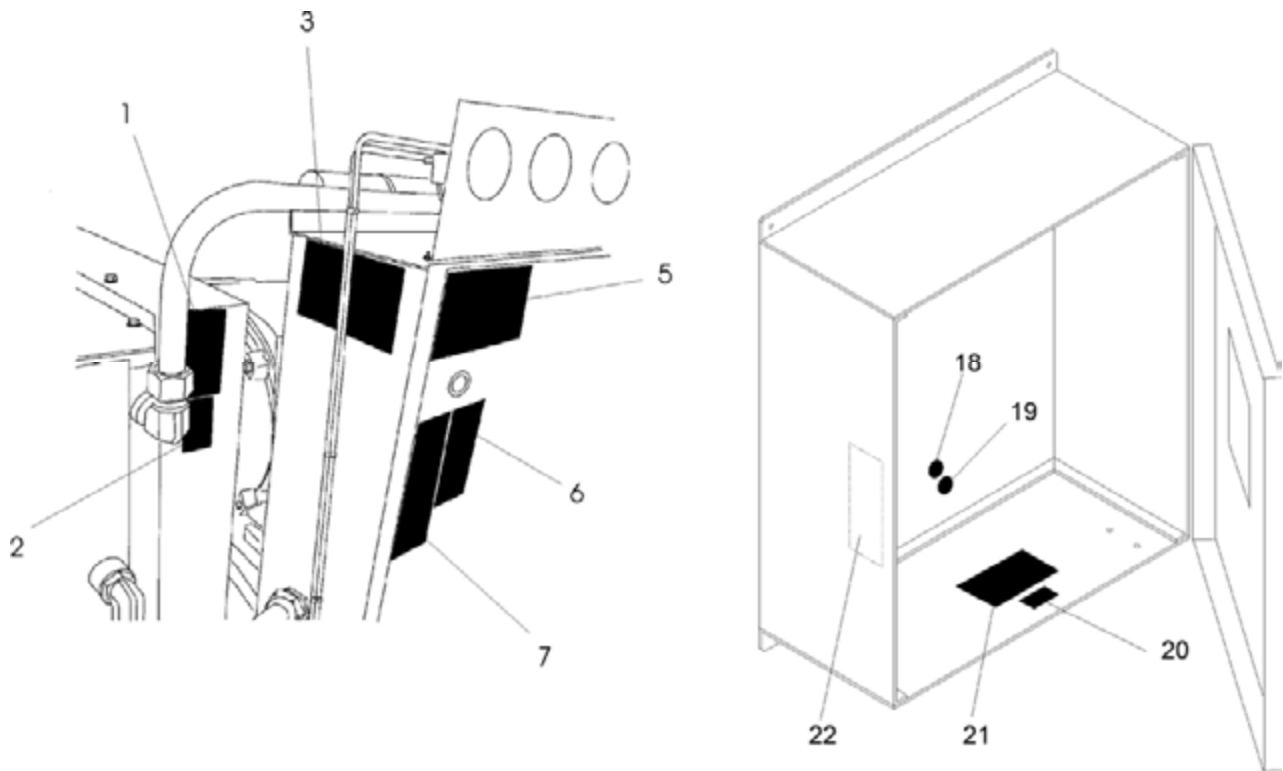
---

**PLEASE NOTE: WHEN ORDERING PARTS, INDICATE SERIAL NUMBER OF COMPRESSOR**

## Section 8

# ILLUSTRATIONS AND PARTS LIST

### 8.14 DECAL LOCATIONS



# ILLUSTRATIONS AND PARTS LIST

---

## 8.14 DECAL LOCATIONS (CONTINUED)

<i>key number</i>	<i>description</i>	<i>part number</i>	<i>quantity</i>
1	sign, warning sever fan	049855	2
2	sign, warning sever fan port	049965	1
3	decal, instument pnl universal	02250051-303	1
4	decal, instrument pnl universal	02250051-301	1
5	decal, electrocution hazard international	02250077-472	1
6	sign, danger electrocution	049850	1
7	decal, warning auto start	250017-903	1
8	decal, warning auto start	041065	1
9	decal, ISO 9001	02250057-624	1
10	decal, LS-10 2" high	02250060-916	1
11	decal, Sullair	02250059-054	2
12	sign, warning "food grade" lube	250003-144	1
13	sign, danger air breathing	250027-935	1
14	decal, maintenance kit LS-10	02250103-910	1
15	sign, warning compressor fluid fill cap	049685	1
16	decal, warning mixing fluids	02250110-891	1
17	decal, fluid Sullube	02250069-389	1
	Sdecal, fluid 24KT	02250069-395	1
	Sdecal, fluid SRF 1/4000	02250069-391	1
18	decal, protective earth ground	02250075-045	1
19	decal, PE designation	02250075-540	1
20	decal, danger hi voltage	042218	1
21	decal, 460 voltage international <b>(I)</b>	02250069-399	1
22	decal, warning auto start <b>(II)</b>	250017-903	1
23	decal, 24 KT <b>(III)</b>	02250061-016	1

(Continued on page 89)

**(I)** Compressor voltage may vary. Consult Factory with machine serial number.

**(II)** Decal is located where shown, but on the inside of the control box (left side).

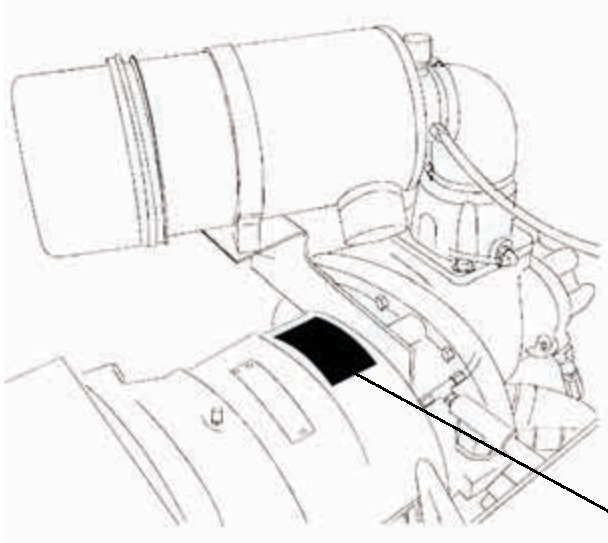
**(III)** Decal used when applicable with 24KT fluid only.

---

**PLEASE NOTE: WHEN ORDERING PARTS, INDICATE SERIAL NUMBER OF COMPRESSOR**

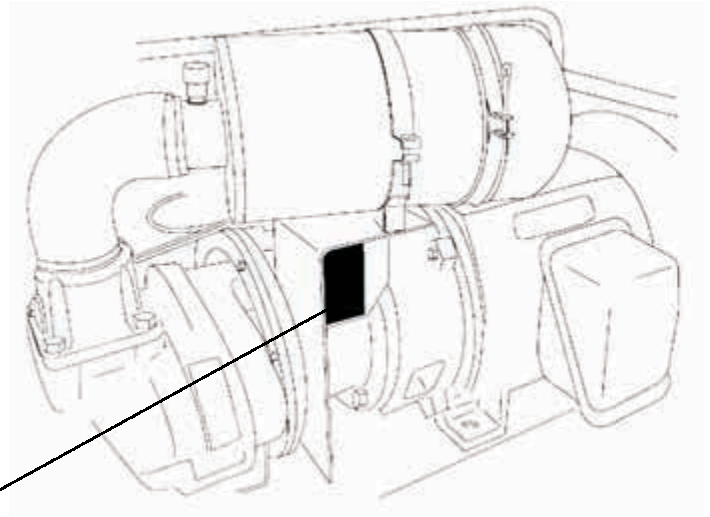
# Section 8 ILLUSTRATIONS AND PARTS LIST

## 8.14 DECAL LOCATIONS

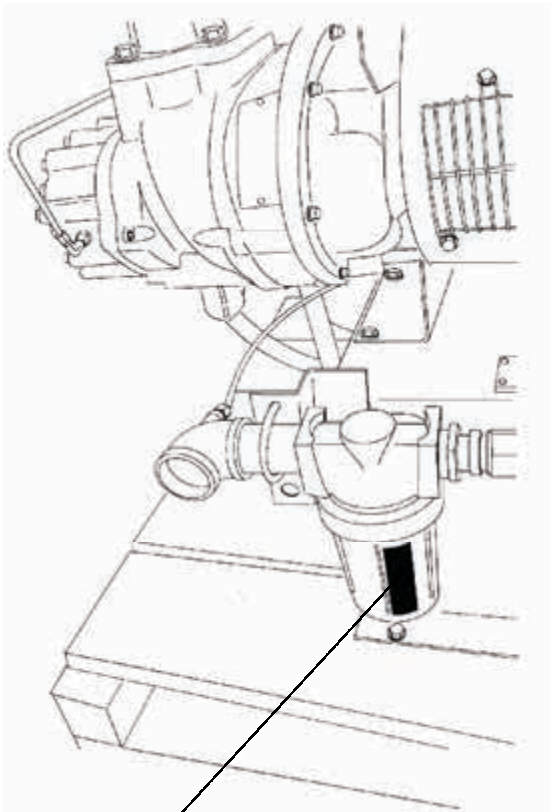


25-30 HP Model

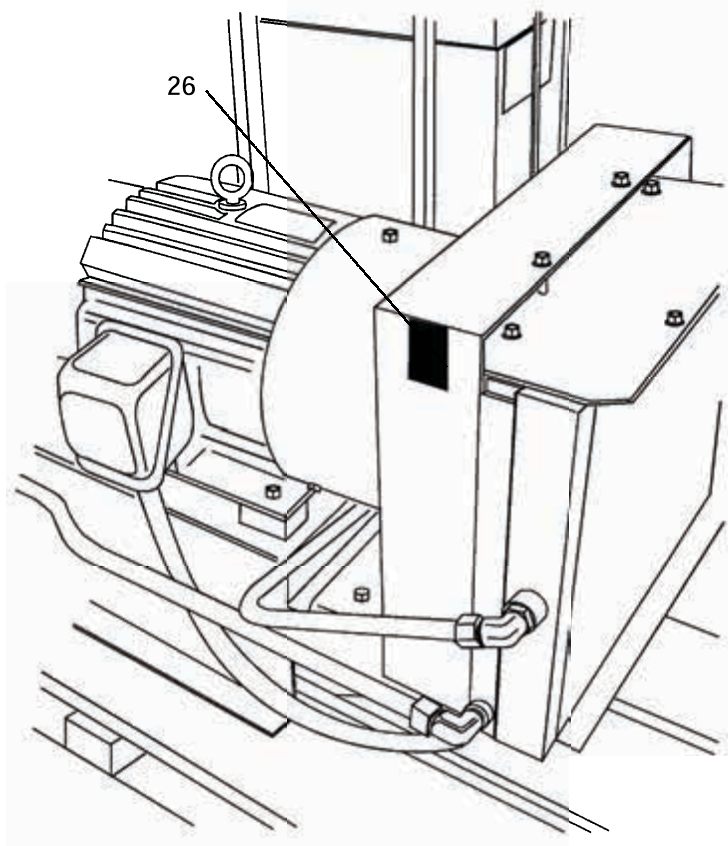
24



40 HP Model



25



26

**ILLUSTRATIONS AND PARTS LIST**

---

**8.14 DECAL LOCATIONS (CONTINUED)**

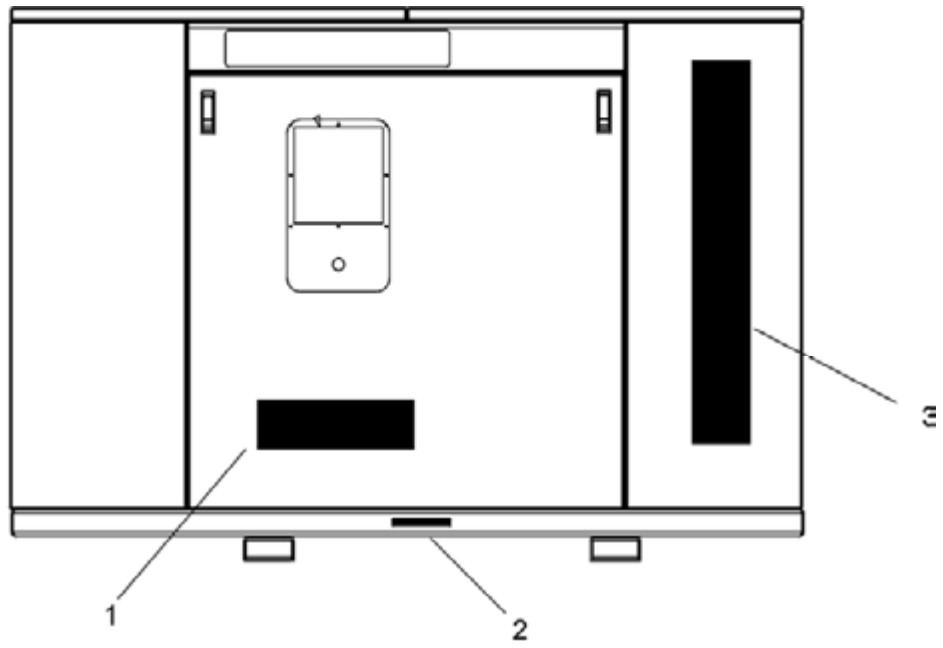
<i>key number</i>	<i>description</i>	<i>part number</i>	<i>quantity</i>
24	sign, warning sever fan	049855	2
25	decal, water drain	250022-810	1
26	sign, warning sever fan port	049965	1

---

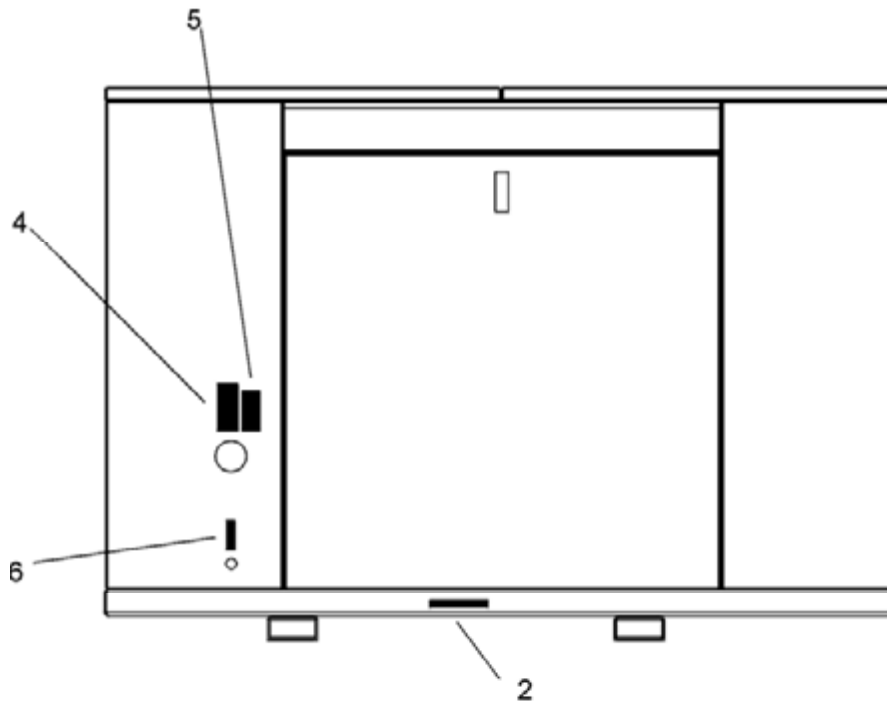
**PLEASE NOTE: WHEN ORDERING PARTS, INDICATE SERIAL NUMBER OF COMPRESSOR**

# ILLUSTRATIONS AND PARTS LIST

## 8.15 DECAL LOCATIONS- ENCLOSURE



FRONT VIEW



REAR VIEW

# ILLUSTRATIONS AND PARTS LIST

---

## 8.15 DECAL LOCATIONS- ENCLOSURE

<i>key number</i>	<i>description</i>	<i>part number</i>	<i>quantity</i>
1	decal, LS-10 2" high	02250060-916	1
2	decal, fork lifting	241814	2
3	decal, Sullair	02250059-054	1
4	sign, warning "food grade" lube	250003-144	1
5	sign, danger air breathing	250027-935	1
6	decal, water drain	250022-810	1

---

**PLEASE NOTE: WHEN ORDERING PARTS, INDICATE SERIAL NUMBER OF COMPRESSOR**













# WORLDWIDE SALES AND SERVICE



**SULLAIR ASIA, LTD.**  
Sullair Road, No. 1  
Chiwan, Shekou  
Shenzhen, Guangdong PRV.  
PRC POST CODE 518068  
Telephone: 755-6851686  
Fax: 755-6853473

**SULLAIR EUROPE, S.A.**  
Zone Des Granges BP 82  
42602 Montbrison Cedex, France  
Telephone: 33-477968470  
Fax: 33-477968499

## **SULLAIR CORPORATION**

3700 East Michigan Boulevard  
Michigan City, Indiana 46360 U.S.A.  
Telephone: 1-219-879-5451  
Fax: (219) 874-1273  
Fax: (219) 874-1835 (Parts)  
Fax: (219) 874-1288 (Service)



Printed in U.S.A.

Specifications Subject To  
Change Without Prior Notice

E99ep